

SAMSUNG
wiSeNET

SMARTCAM A1

User Manual

SNS-R0810W/SNW-R0210SW/SNW-R0130BW

CE 0678 !

Smartcam A1

User Manual

Copyright

©2017 Hanuha Techwin Co., Ltd. All rights reserved.

Trademark

Each of trademarks herein is registered. The name of this product and other trademarks mentioned in this manual are the registered trademark of their respective company.

Restriction

Copyright of this document is reserved. Under no circumstances, this document shall be reproduced, distributed or changed, partially or wholly, without formal authorization.

Disclaimer

Hanuha Techwin makes the best to verify the integrity and correctness of the contents in this document, but no formal guarantee shall be provided. Use of this document and the subsequent results shall be entirely on the user's own responsibility. Hanuha Techwin reserves the right to change the contents of this document without prior notice.

SPECIFY SERVICE INSTRUCTIONS AND WARRANTY TERMS

This device complies with Part 15 of the FCC Rules.

Operation is subject to the following two conditions: (1) this device may not cause harmful interference, and (2) this device must accept any interference received, including interference that may cause undesired operation.

FCC CAUTION:

Any changes or modifications in construction of this device which are not expressly approved by the party responsible for compliance could void the user's authority to operate the equipment.

FCC NOTE:

The manufacturer is not responsible for any radio or tv interference caused by unauthorized modifications to this equipment. Such modifications could void the user's authority to operate the equipment.

This device complies with Industry Canada licence-exempt RSS standard(s). Operation is subject to the following two conditions:

- (1) this device may not cause interference, and
- (2) this device must accept any interference, including interference that may cause undesired operation of the device.

Operational Description

The operational description shall fulfil the requirements of Rule Part 2.1033(b)(4). The rule part requires, "A brief description of the circuit functions of the device along with a statement describing how the device operates. This statement should contain a description of the ground system and antenna, if any, used with the device".

The above requirement has been further interpreted by the FCC to mean that the description shall:

- a. be an operational or technical description of how the device operates, is modulated and meets requirements;
- b. describe the EUT completely. What is it (in plain English as well as technical terms)? Give a clear, concise functional description of device operation.
- c. always describe the signal, such as modulation type, pulse repetition rate, signal type and information being sent. Describe all modulation types and all data rates.

Instructions & Warranty

The manufacturer is not responsible for any loss or radio/TV interference caused by unauthorized modification of the product.

Such modification will void the warranty of the product as well as the user's right of use.

WARNING

- The product must be assembled and installed by an adult.
- Before using, read all instructions on this manual thoroughly and follow operational instructions, warnings on this manual and printed on the product.
- To avoid entangled power cord, do not place it around the baby bed or other infant furniture. Keep this product and its power cord out of children's reach.
- Especially, the power cord should be installed carefully while keeping it out of children's reach.
- Never use the product near bath tub, sink, washing machine and in wet basement to avoid moisture.
- The product is not designed for medical monitoring, and requires a grown-up's protective supervision on its use.
- To avoid overheating of the product, do not expose the product to direct sunlight; do not install or use near a heat source such as heater, radiator, cooking devices (ex: electric stove or oven) and other warming devices (ex: audio amplifier, TV, etc.).
- Make sure to keep ventilated while using the product.
Avoid pillar or furniture that may block ventilation, when installing the product.
- Make sure to use the power adaptor provided. If used with unidentified adaptor, it may damage the product. The power adaptor must be used with regular household electric supply.
- Avoid sharp, pointed objects around the adaptor's cable, not to damage the cable.
- Be warned and never hold the cable's stripped part when connecting / disconnecting the adaptor to/from the wall outlet.
- To avoid entangled cable lines, avoid using cable extension for adaptor's power cord.
- The product's servicing is allowed only to authorized Hanwha Techwin service personnel.

- When using the product for children's care, be careful to keep the product out of children's reach.
- Accessories and small parts of the product should be stored keeping out of children's reach.
- The product is not designed to replace responsibility of human supervision on children.
- The product is not equipped with device of immediate notification to adult with accidental/sudden children's move; it requires periodic checks and human supervision.
- This appliance and its antenna must not be collocated or operation in conjunction with any other antenna or transmitter. A minimum separation distance of 20 cm must be maintained between the antenna and the person for this appliance to satisfy the RF exposure requirements.
- Please note that the content of a micro SD card used for other purposes may be deleted when it is mounted in the product.

PRECAUTIONS

- Recommended micro SD card
 - It is recommended to use a MLC for higher data density and reliability of recording.
- We recommend that you use the provided batteries, or well-known brand batteries such as Panasonic, Energizer, or Duracell.
Use of counterfeit or low-quality batteries increases the risk of camera malfunction and the possibility of fire.
- We do not recommend using rechargeable batteries for the Outdoor, Battery-Powered Camera.
It increases the risk of camera malfunction and the possibility of fire.
- Station Camera is not weatherproof.
For indoor use only.

Contents

GETTING STARTED

Features	5
What's Included	6
Part names and functions	7

INSTALLATION & NETWORK CONNECTION

Installation	9
Network Connection and Settings.....	15

APPENDIX

Specifications	17
Troubleshooting	23

GETTING STARTED

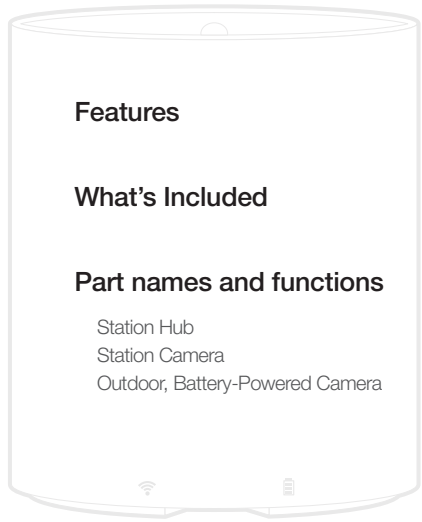

Features

- **Wireless camera**
 - You can install a camera at your desired position without a cable.
- **Easy to install**
 - The Wi-Fi Direct button allows easy connection to a wireless router.
- **Remote monitoring**
 - You can monitor your camera remotely, at any time and from any location, using your smartphone.
- **Real-time alarm**
 - When a motion and sound are detected, your smartphone will generate real time alarms.
- **Saving in SD card**
 - When an event occurs, the user can save the video in their SD card.
- **Downloading a recorded video**
 - You can download motion detection/audio detection/manually recorded video to the user's smartphone (Android).
- 5 • **Camera pan feature**
 - When the station camera is placed on the station hub, the camera can be moved to the left and right to monitor a wider area.
- 6 • **Cameras that can be added**
 - You can connect an additional camera to a station hub.
- 7
- 7
- 8
- 8

What's Included

Check for components when opening the product package.

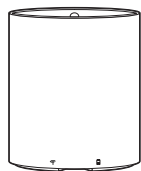

Station Hub (SNS-R0810W)



Station Camera (SNW-R0210SW)

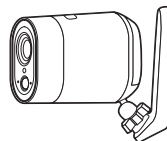

Outdoor, Battery-Powered Camera (SNW-R0130BW)

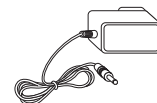

Power adapter



Battery (CR123)



LAN Cable (3.28ft)

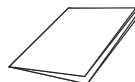

Quick Start Guide

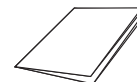

Warranty Card

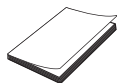

GPL License



Tapping screw



Plastic anchor

Part names and functions

Station Hub

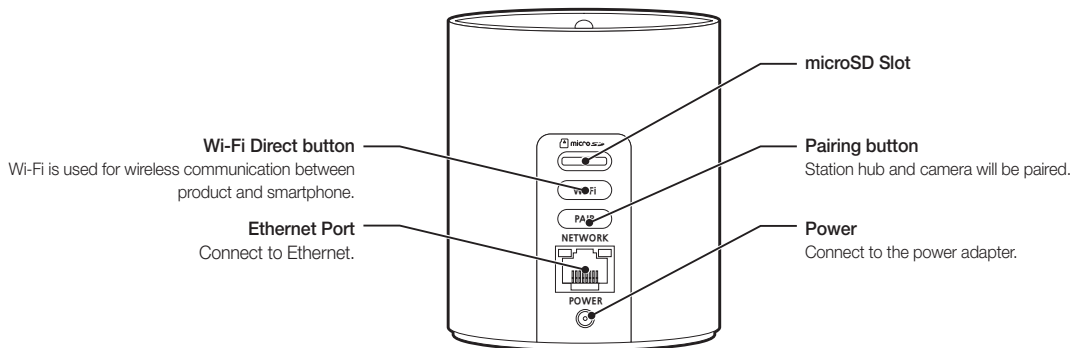
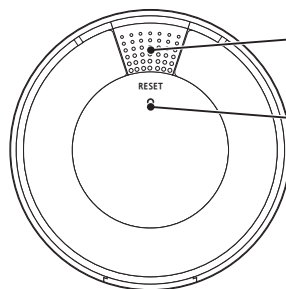
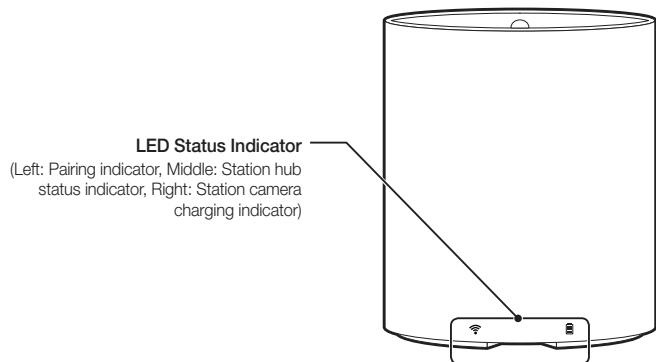

Station Camera

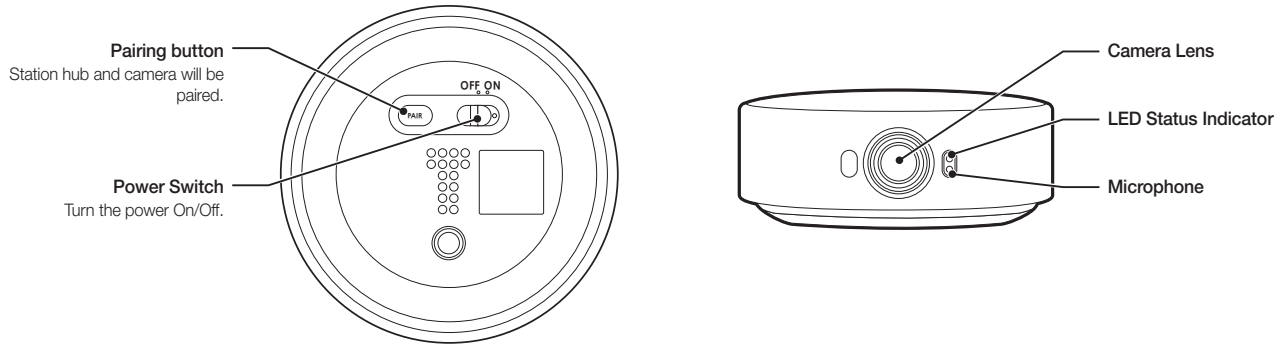

Outdoor, Battery-Powered Camera

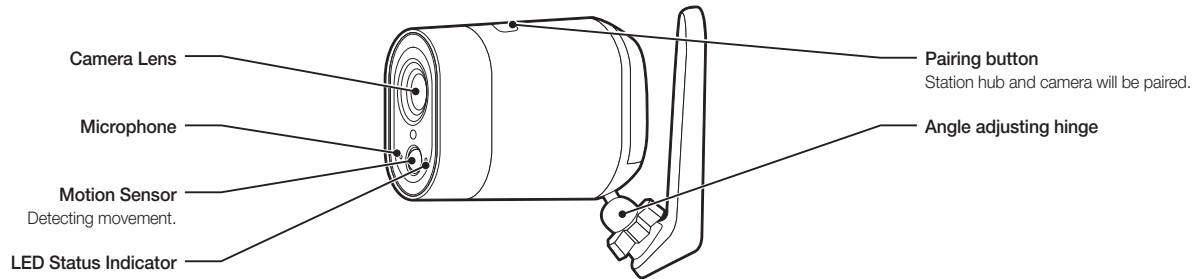

INSTALLATION & NETWORK CONNECTION

Installation	9
Precautions	9
Registering a station hub	10
Power connection on camera	11
Camera Registration	12
Camera Installation	12
Replace battery	14
Network Connection and Settings	15
Precautions	15
Connecting via LAN cable	15
Connection using the Wi-Fi Direct function	16

Installation

Precautions

1. As this product works on a Wi-Fi network, video receiving may be unstable if there is an obstacle (metal, wall, door) in the use environment, or if the product is receiving interference from another Wi-Fi device nearby. Install the station hub and the camera at a position that ensures good video reception, considering the Wi-Fi network environment.
2. Do not install the device under direct sunlight or other strong light sources. Place it where there is good visibility.
3. Do not install it in a place where there are a lot of obstacles.
4. When wiping the surface of the product, a clean and soft dry cloth should be used. Moist the dry cloth with water and wring it thoroughly to remove extra water.
(Do not use cleaners containing alcohol or solvents, detergents containing surface active ingredients, and skin care products or oil, as they can cause damage or deformation of the product.)
5. Do not install the product in places where there are or may be chemicals or traces of oil. Cooking oils like soybean oil can cause damage or deformation of the product, so please do not install the product near the kitchen or the kitchen counter. This may cause damage to the product.
6. Please be careful not to get chemical substances on the surface of the product when installing the product.
Some detergents or chemical solvents like adhesives can cause serious damage to the surface of the product.
7. The function and performance of the product may not be guaranteed if the product is not installed/uninstalled by the recommended procedure.

Registering a station hub

Power connection

Plug-in the product power adaptor to the wall outlet and connect the product as shown.



- Make sure to use the provided power adaptor. If you use an adaptor other than the power supply adaptor provided in our package, the product may not operate properly.
- It takes about 30 seconds to reboot the product completely.
- When the product is turned on, the LED blinks red.

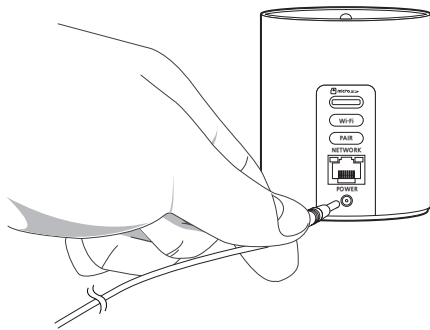

❖ LED status

LED indicator shows operational status with colors.

Refer to table below for detailed meaning of the LED indicator.

Color	Status
Red	Booting up
Red Blinking	Booting completed / Establishing network connection
Yellow	Enabling Wi-Fi Direct
Blue Blinking	Connecting to the network.
Blue	Local connection established
Green	Connection to server completed / Normal operation
Purple	Updating firmware

Network connection

In a location with a strong Wi-Fi signal and no interference, use Wi-Fi communication.

In a location with a weak Wi-Fi signal and heavy interference, use Ethernet communication.

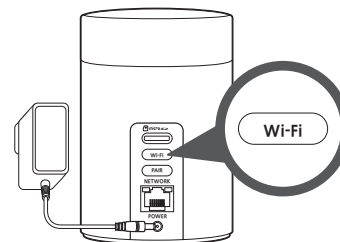

Creating an Account and Registering a Station Hub

With the Wisenet SmartCam+ app, users can monitor the SmartCam camera from a mobile device.

1. Go to Google Play/App Store and search for "Wisenet SmartCam+".
2. Download the application and install it on your mobile device.
3. Run the downloaded application.
4. After completing member registration, register the station hub as instructed on the screen.



- For more details, refer to Wisenet SmartCam+ mobile guide.

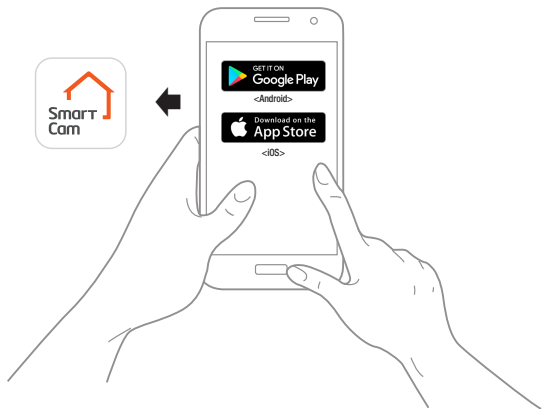

Power connection on camera

Station camera

Turn on the power switch at the bottom of the camera.



- The power may not turn on if the battery is low. In this case, dock it on the station hub to recharge and try again.

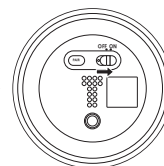

Outdoor, Battery-Powered Camera

1. As shown in the figure, push the switch with your left hand and push the cover with your right hand.

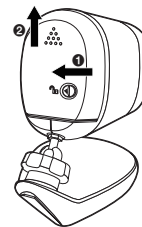

2. Insert the batteries.



- Insert the batteries with correct electrode after checking the electrode.

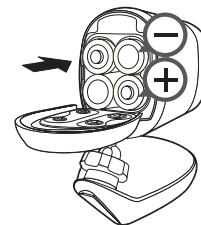

3. Close the battery cover.

Camera Registration

Pairing

1. Set the station hub and camera in close range of each other. (about 30cm~100cm)
2. Press and hold the **[PAIR]** button on the camera for 3 seconds, and press and hold the **[PAIR]** button on the station hub for 3 seconds.
3. When pairing is complete, the following indicators will be displayed: Blue ON (station hub) Green ON (station camera), Green turns on for 5 seconds and then turns off (outdoor battery camera)



- Repeat steps 1 through 3 to pair an additional station hub and camera.
- Before pairing, dock the station camera on the station hub to charge it sufficiently.

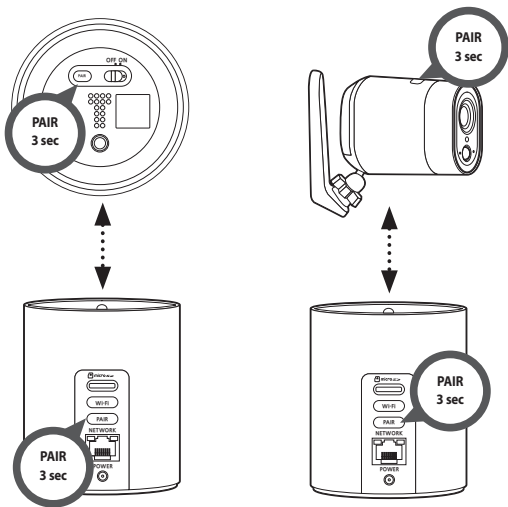

Camera Installation

Station camera

Dock it on the station hub or place it on a shelf or a flat place.

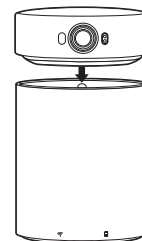

When the camera is docked on the station hub, the camera battery will start to be charged. Pan (move left/right) and auto tracking are available.



- When you remove the camera from the station hub, the camera (with the battery fully charged) can operate for 2 to 3 hours.

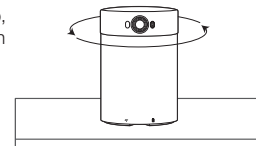

Outdoor, Battery-Powered Camera

- ! Check whether or not the camera installation position is suitable for good video reception.

1. As shown in the figure, remove the bracket bottom using a simple tool.

- 📄 If you are mounting the camera on the wall, carefully separate the bracket cover from the bracket.

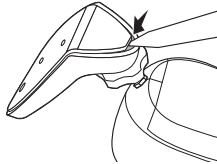

2. Place the bracket cover against the wall where the camera will be mounted and mark the position of the screw holes.

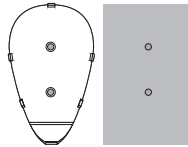

3. Use a drill on the marked positions, and drill holes to a depth of 3 cm. Clean the holes after drilling.

- ! It is recommended to use a drill bit (Ø5) that is suitable for the wall material.
- Be careful not to get injured while drilling.

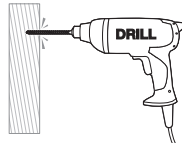

4. Insert an anchor for the two holes. Fully insert the anchors by gently tapping the anchor head with a hammer or rubber mallet.

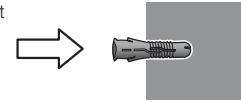

5. Match the bracket cover to the holes on the wall and fasten the screws.

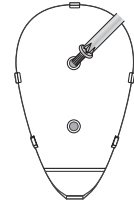

6. Press the bracket body to the bottom to assemble.
7. Adjust the angle of view.

- ! Do not use force to adjust it. Unscrew the lever and adjust it after checking the location of the groove. Re-tighten the lever.

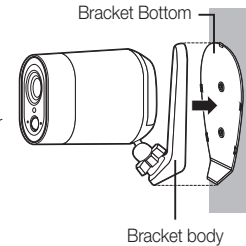

Adjusting the Camera Angle

1. Turn the bracket lever counterclockwise.
2. Adjust the angle adjustment hinge to adjust the camera's picture taking angle.
3. Tighten the bracket lever by turning it clockwise.

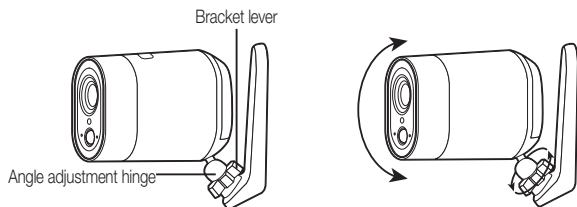

Replace battery

Outdoor, Battery-Powered Camera

1. As shown in the figure, insert a simple tool into the gap at the bottom of the bracket and remove the camera from the wall.

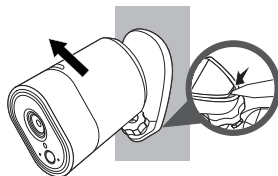

2. Rotate the bracket 180° to open the battery cover.



- To open the battery cover, push the switch with your left hand and push the cover with your right hand.

3. Replace the battery.

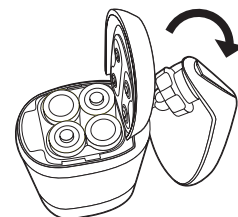

4. Return the bracket direction and press the bracket body to the bottom to assemble.

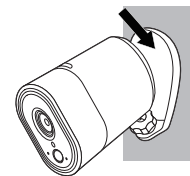

Network Connection and Settings

Precautions

- The wireless network access may fail, depending on the communications environment.
In this case, a wired connection is recommended.
- For details about the network settings and password, contact your network administrator or service provider.
- For a specific Internet service requiring user authentication, you may not access the service. If this is the case, contact the service provider.
- Do not access the unauthorized network.
- The farther the distance from the Wireless Access Point, the longer time the network connection may take.
- If you fail to access the selected wireless network, try a different Wireless Access Point to make access.
- For more information about the router or the wireless connection, refer to the documentation of the router or contact the router manufacturer.
- If the product is connected to a multiple-Wireless Access Point network environment, some video packets may be lost, depending on the network traffic load.
- According to the network policy of the Internet service provider (UDP blocking), video reception may be limited to 7 minutes.
- In addition to the above two situations, you may encounter a network delay or interruption due to the network conditions.
- Some hubs can have compatibility issues.

Connecting via LAN cable

If you do not have a Wireless Access Point, you must connect the product using LAN cable directly to your home router.

1. Connect the power adapter to the product.
2. Connect the LAN cable to the product and to the home router as shown below.

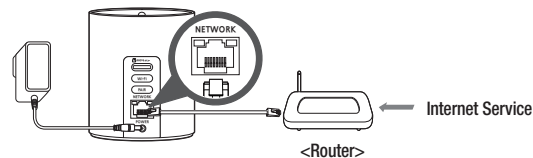

3. Upon turning on the power, the LED will illuminate in red, and the red light blinks when boot-up is completed.
4. When the product is connected to the router, the LED will illuminate in blue. (Connection waiting time: Maximum of 30 seconds)
If the LED does not illuminate in blue, repeat from the second step and check it.
5. Register the product following the instructions in the mobile guide.
6. When the product is connected to the server, the LED will illuminate in green.



- It is recommended to set the router to DHCP(Dynamic Host Configuration Protocol) server.

Connection using the Wi-Fi Direct function

What is Wi-Fi Direct?

If you use Wi-Fi Direct, the product can be connected to the router without using wires.

1. Connect the power adapter to the product.
2. When the power is connected, the power status LED lights up in red and starts blinking when boot-up is complete.
3. If you press and hold the Wi-Fi Direct button for 5 seconds, the LED will illuminate in yellow.

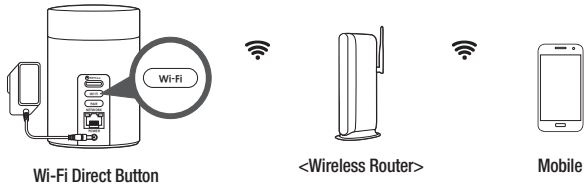

4. Register the product following the instructions in the mobile guide.
5. When the product is connected to the server, the LED will illuminate in green.



- You can connect in relay mode if the router doesn't have UPnP. Configuration may differ depending on the router model. Please refer to the router manual.
- Please contact the service provider if you have difficulty connecting to the Internet.

APPENDIX

03



Specifications

Specifications

Station Hub	
Item	Description
Pan Rotate	
Pan Range	350° (-175°~175°)
Preset	9ea
Tracking	Off/On
Operational	
Camera Channel	Max 3ea
Alarm Triggers	Motion Detection, Audio Detection, Motion Zone Detection, Auto Tracking, Low Battery, Low signal notification
Memory Slot	Max 128GB(MLC type or higher)
Recording Format	AVI
Recording Type	Continuous, Event(Motion, Audio, Auto Tracking), Scheduled
Indicate LED	Wi-Fi Status(3 color LED), Pairing Status(blue), Recharging Status(blue)
Button	Factory reset(Pin hole button), Pairing(Tact type), Wi-Fi Direct(Tact type)

17

17

21

23

04

Appendix

Station Hub	
Item	Description
Network	
Ethernet	RJ-45 (10/100BASE-T)
Wireless	WiFi 802.11 a/b/g/n/ac (Dual Band, 2.4GHz/5GHz) for Wi-Fi Router connection WiFi 802.11 b/g/n (Single Band, 2.4GHz) for Camera connection RF(Sub 1GHz) for Battery camera
Audio I/O	Built-in Speaker
Audio Communication	2-way audio / Half duplex
IP	IPv4
Protocol	TCP/IP, UDP/IP, RTP(UDP), RTP(TCP), RTSP, NTP, HTTP, HTTPS, SSL, DHCP, SMTP, ICMP, ARP, DNS, UPnP
Security	HTTPS(SSL) Login Authentication Digest Login Authentication
Streaming Method	Unicast
Max. User Access	1920x1080 : 1, 1280x720 : 2, 640x360 : 4
Supported mobile OS	Android : 5.0 or higher iOS : 8.0 or higher
Environmental	
Operating Temperature / Humidity	0°C ~ 40°C(+32°F ~ +104°F) / Less than 90% RH
Storage Temperature / Humidity	-30°C ~ +60°C (-22°F ~ +140°F) / Less than 90% RH

Station Hub	
Item	Description
Electrical	
Input Voltage / Current	12V-1.5A
Power Consumption	10W(Max)
Power Connector	DC

Station Camera	
Item	Description
Video	
Imaging Device	1/3" CMOS
Min. Illumination	Color : 0.3 Lux B/W : 0 Lux with IR
Operational	
IR LED	850nm
Viewable Length	7m(24ft)
Camera Title	Time display (Off/On)
Day & Night	True D/N
Wide Dynamic Range	HDR
Contrast Enhancement	Auto
Digital Noise Reduction	Support (2D+3D Noise Filter)
Motion Detection	Off / On
Audio Detection	Off / On
Digital Zoom	4x(Mobile)
Flip / Mirror	Off / On
Alarm Triggers	Motion Detection, Audio Detection, Motion Zone Detection, Auto Tracking, Low Battery
Indicate LED	3 Color LED 1ea(Connection Status, Low battery)
Button	Power (Slide type), Pairing(Tact type)

Station Camera	
Item	Description
Network	
Wireless	WiFi 802.11 b/g/n (Single Band, 2.4Ghz)
Video Compression Format	H.264
Resolution	1920x1080 / 1280x720 / 640x360
Streaming Capability	Multiple Streaming (Up to 4 Profiles)
Audio I/O	Built-in Mic
Audio Compression Format	G.711 u-law
Environmental	
Operating Temperature / Humidity	0°C ~ 40°C(+32°F ~ +104°F) / Less than 90% RH
Electrical	
Input Voltage / Charging Voltage	3.6V/4.2V
Battery Capacity	Max 2600mAh
Battery Life	2~3 hours (Continuous Streaming)

Outdoor, Battery-Powered Camera	
Item	Description
Video	
Imaging Device	1/4" CMOS
Operational	
IR LED	850nm
Viewable Length	7m(24ft)
Motion(PIR) sensor Angle	H : 110° ↑
Digital Noise Reduction	Support (2D+3D Noise Filter)
Motion Detection	Off / On (PIR sensor detection)
Digital Zoom	4x(Mobile)
Flip / Mirror	Off / On
Alarm Triggers	Motion Detection, Low battery
Indicate LED	2 Color LED
Button	Pairing
Network	
Wireless	WiFi 802.11 b/g/n (Single Band) RF(Sub 1GHz)
Video Compression Format	H.264
Resolution	1280x720
Audio I/O	Built-in Mic
Audio Compression Format	G.711 u-law
Streaming Method	Unicast

Outdoor, Battery-Powered Camera	
Item	Description
Environmental	
Operating Temperature / Humidity	-10°C ~ 50°C(+14°F ~ +122°F) / Less than 90% RH
Ingress Protection	IP65
Electrical	
Input Voltage	3V
Battery Type	CR123
Battery Capacity	3000mAh
Battery Life	4~6 months (15 events/day, 10sec recording, only for event)
Battery Quantity	4ea

Product Appearance

Station Hub

unit: mm (inch)

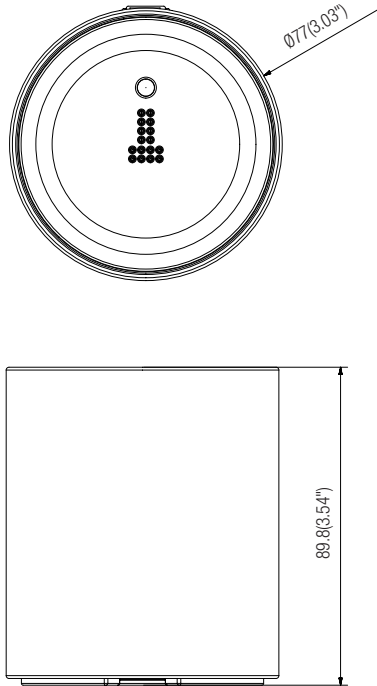

Station Camera

unit: mm (inch)

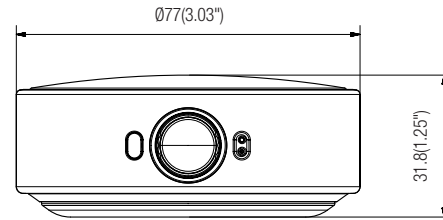

Outdoor, Battery-Powered Camera

unit: mm (inch)

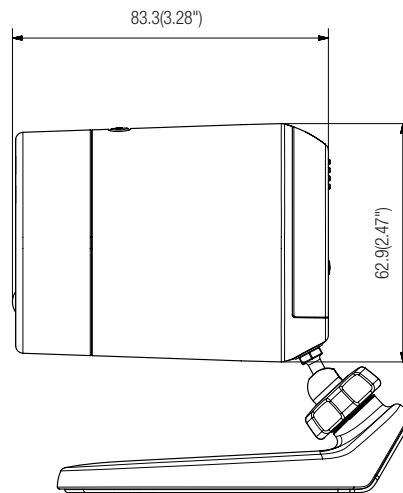
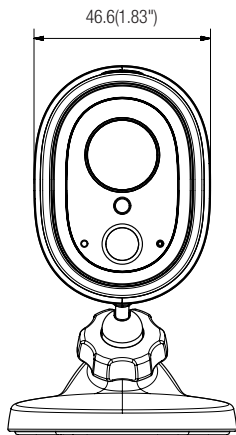

Troubleshooting

If you encounter a problem with your system, see the table below to solve the problem as quickly and easily as possible. Please follow the instruction below:

Problem	Action
I forgot my user ID/ password.	<ul style="list-style-type: none"> - Move to "Log-in page → Forgot your ID/Password?", and enter the registered e-mail address to which we will send you the user ID and/or a new password. It can be spammed out depending on the policy of the email server. After logged in, it is advisable to change the temporary password provided.
Product is not connected to the wireless hub.	<ul style="list-style-type: none"> - If the green light on the product state LED turns off frequently, it may be because the product is installed in an environment with a poor wireless Internet connection. In this case, a wired connection is recommended. - Check the password for the wireless hub and try again.
After logged in, I failed to register the product.	<ul style="list-style-type: none"> - Check whether the serial number entered matches the label on the product. - Enter the correct password for the product registered again and try to register the product again. - Check whether the LED light of the product is yellow. - If this fails to resolve the problem, factory reset the product and repeat the procedure from the beginning. (To factory reset the product, press and hold the RESET button on the product for 10 seconds. The product will be restarted when the product is factory reset.)

Problem	Action
The video from the camera is temporarily lost.	<ul style="list-style-type: none"> - The video from the camera can be delayed according to a network delay. Check if the product and the camera are far apart.
No sound is output from the video.	<ul style="list-style-type: none"> - Click the Voice icon in the video playback page, or check if the voice is turned On in your smart phone app. - Some internet service providers do not support audio outputs in relay mode.
I want to change my password and/or email address.	<ul style="list-style-type: none"> - Change the account information after logging into Wisenet SmartCam+. For more details, refer to the mobile guide.
Product will be connected in a relay mode.	<ul style="list-style-type: none"> - Check the UPnP setting of the router. - A network upload speed of at least 3.5Mbps (1080p) is recommended. - Depending on the policy of your service provider, you can access in relay mode.
No event is detected.	<ul style="list-style-type: none"> - The Outdoor, Battery-Powered Camera cannot detect additional events while detecting an event and transmitting to the station hub, and may be subject to a time delay during live monitoring.
A battery replacement push notice is generated.	<ul style="list-style-type: none"> - The Outdoor, Battery-Powered Camera is displayed as activated on the camera list even if it is fully discharged, so please replace the battery when a push notice is received.
Motion event is not recorded.	<ul style="list-style-type: none"> - The Outdoor, Battery-Powered Camera detects the movement of an object using a PIR sensor, but it may fail to record the movement of an object if it approaches to the camera and passes quickly.



Hanwha Techwin cares for the environment at all product manufacturing stages, and is taking measures to provide customers with more environmentally friendly products. The Eco mark represents Hanwha Techwin's devotion to creating environmentally friendly products, and indicates that the product satisfies the EU RoHS Directive.



Correct Disposal of This Product

(Waste Electrical & Electronic Equipment)

(Applicable in the European Union and other European countries with separate collection systems)

This marking on the product, accessories or literature indicates that the product and its electronic accessories (e.g. charger, headset, USB cable) should not be disposed of with other household waste at the end of their working life. To prevent possible harm to the environment or human health from uncontrolled waste disposal, please separate these items from other types of waste and recycle them responsibly to promote the sustainable reuse of material resources.

Household users should contact either the retailer where they purchased this product, or their local government office, for details of where and how they can take these items for environmentally safe recycling.

Business users should contact their supplier and check the terms and conditions of the purchase contract. This product and its electronic accessories should not be mixed with other commercial wastes for disposal.

Head Office

6, Pangyo-ro 319 beon-gil, Bundang-gu, Seongnam-si,

Gyeonggi-do, 463-400 Rep. of KOREA

Tel : +82.70.7147.8753 Fax : +82.31.8018.3740

www.wisenetlife.com

Hanwha Techwin America

500 Frank W. Burr Blvd. Suite 43 Teaneck, NJ 07666

Tel +1.877.349.3149

www.wisenetlife.com

Hanwha Techwin Europe

Heriot House, Heriot Road, Chertsey, Surrey, KT16 9DT, United Kingdom

Tel#1 00800.801.08022

Tel#2 +31.77.326.1580

www.wisenetlife.com
