

TEST REPORT

EN 301 893 V2.1.1

Equipment under test HOME CAMERA

Model name SNH-P6415BN

Derivative model SNH-P6416BN, SNH-C6415BN,
SNH-C6415BNB, SNH-C6416BN,
SNH-C6416BNB

Applicant Hanwha Techwin Co., Ltd.

Manufacturer Hanwha Techwin (Tianjin) Co., Ltd.
Hanwha Techwin Security Vietnam Co.,Ltd.
D-TECH Co.,Ltd.

Date of test(s) 2018.12.03 ~ 2018.12.17



Date of issue 2018.12.18

Issued to

Hanwha Techwin Co., Ltd.
6, Pangyo-ro 319 Beon-gil, Bundang-gu Seongnam-si,
Gyeonggi-do, 13488, Korea
Tel: +82-70-7147-8361/ Fax: +82-31-8108-3717

Issued by

KES Co., Ltd.
C-3701, 40, Simin-daero 365beon-gil, Dongan-gu, Anyang-si,
Gyeonggi-do, 14057, Korea
473-21, Gayeo-ro, Yeosu-si, Gyeonggi-do, Korea
Tel: +82-31-425-6200 / Fax: +82-31-424-0450

Test and report completed by :	Report approval by :
	
Young-Jin Lee Test engineer	Hyeon-Su, Jang Technical manager

This test report is not related to KOLAS.



Revision history

Revision	Date of issue	Test report No.	Description
-	2018.12.18	KES-RF-18T0119	Initial

This report shall not be reproduced except in full, without the written approval of KES Co., Ltd.
The results shown in this test report refer only to the sample(s) tested unless otherwise stated.
The authenticity of the test report, contact shchoi@kes.co.kr

TABLE OF CONTENTS

1.	General information	4
1.1.	EUT description	4
1.2.	Frequency/channel operations	5
1.3.	Directional antenna gain.....	6
1.4.	Information about derivative model	6
2.	Summary of tests	7
3.	Application form for testing	8
3.1.	Information as required by EN 301 893 V2.1.1, clause 5.4.1.....	8
3.2.	Additional information provided by the manufacturer	22
3.3.	List of ancillary and/or support equipment provided by the manufacturer.....	22
4.	Test results	23
4.1.	Transmitter unwanted emissions outside the 5 GHz RLAN bands	23
4.2.	Receiver spurious emissions.....	30
4.3.	Centre frequencies	37
4.4.	Nominal channel bandwidth and Occupied channel bandwidth.....	45
4.5.	RF output power, Transmit Power Control (TPC) and power density.....	49
4.5.1	RF output power	49
4.5.2	Power spectral density.....	56
4.6.	Transmitter unwanted emissions within the 5 GHz RLAN bands	64
4.7.	DFS (Dynamic Frequency Selection).....	77
4.8.	Adaptivity.....	86
4.9.	Receiver blocking.....	94
	Appendix A.....	97
	Appendix B.....	99
	Appendix C.....	101

1. General information

Applicant: Hanwha Techwin Co., Ltd.
Applicant address: 6, Pangyo-ro 319 Beon-gil, Bundang-gu Seongnam-si,
Gyeonggi-do, 13488, Korea
Test site: KES Co., Ltd.
Test site address: C-3701, 40, Simin-daero 365beon-gil, Dongan-gu, Anyang-si,
Gyeonggi-do, 14057, Korea
473-21, Gayeo-ro, Yeosu-si, Gyeonggi-do, Korea
Rule part(s): EN 301 893 V2.1.1
Test device serial No.: Production Pre-production Engineering

1.1. EUT description

Equipment under test WISENET SMARTCAM
Frequency range 2 402 MHz ~ 2 480 MHz (LE)
2 412 MHz ~ 2 472 MHz (11b/g/n_HT20)
2 422 MHz ~ 2 462 MHz (11n_HT40)
5 180 MHz ~ 5 240 MHz (11a/n_HT20, 11ac_VHT20)
5 190 MHz ~ 5 230 MHz (11n_HT40 , 11ac_VHT40)
5 210 MHz (11ac_VHT80)
5 260 MHz ~ 5 320 MHz (11a/n_HT20, 11ac_VHT20)
5 270 MHz ~ 5 310 MHz (11n_HT40 , 11ac_VHT40)
5 290 MHz (11ac_VHT80)
5 500 MHz ~ 5 720 MHz (11a/n_HT20, 11ac_VHT20)
5 510 MHz ~ 5 710 MHz (11n_HT40 , 11ac_VHT40)
5 530 MHz ~ 5 690 MHz (11ac_VHT80)
Model: SNH-P6415BN
Derivative model SNH-P6416BN, SNH-C6415BN, SNH-C6415BNB,
SNH-C6416BN, SNH-C6416BNB ¶
Modulation technique WIFI : DSSS, OFDM
BT : GFSK
Antenna specification Antenna type(2.4GHz WIFI) : Chip antenna, Peak gain : 3.50 dBi
Antenna type(BT, 5GHz WIFI) : Chip antenna, Peak gain : 3.94 dBi
Power source AC 230 V Adaptor (Output : DC 5.0V//2.0A)

- Number of channels
- 2 402 MHz ~ 2 480 MHz (LE) : 40ch
 - 2 412 MHz ~ 2 472 MHz (11n_HT20) : 13ch
 - 2 422 MHz ~ 2 462 MHz (11n_HT40) : 9ch
 - 5 180 MHz ~ 5 240 MHz (11a/n_HT20, 11ac_VHT20) : 4ch
 - 5 190 MHz ~ 5 230 MHz (11a/n_HT40, 11ac_VHT40) : 2ch
 - 5 210 MHz (11ac_VHT80) : 1ch
 - 5 260 MHz ~ 5 320 MHz (11a/n_HT20, 11ac_VHT20) : 4ch
 - 5 270 MHz ~ 5 310 MHz (11a/n_HT20, 11ac_VHT40) : 2ch
 - 5 290 MHz (11ac_VHT80) : 1ch
 - 5 500 MHz ~ 5 720 MHz (11a/n_HT20, 11ac_VHT20) : 12ch
 - 5 510 MHz ~ 5 710 MHz (11a/n_HT20, 11ac_VHT40) : 6ch
 - 5 530 MHz ~ 5 690 MHz (11ac_VHT80) : 3ch

Note:

1. The manufacturer is declared the extremes of operating temperature range and Operating voltage range as follows:

Operating voltage range DC 207 V ~ AC 240 V

Operating temperature rang -10 to +50

1.2. Frequency/channel operations

Ch.	Frequency (MHz)	Ch.	Frequency (MHz)	Ch.	Frequency (MHz)
36	5 180	52	5 260	100	5 500
44	5 220	56	5 280	116	5 580
48	5 240	64	5 320	140	5 700

Table 1.2-1. 802.11a/an/ac_HT20/VHT20 mode

Ch.	Frequency (MHz)	Ch.	Frequency (MHz)	Ch.	Frequency (MHz)
38	5 190	54	5 270	102	5 510
46	5 230	62	5 310	118	5 590
				134	5 670

Table 1.2-2. 802.11an/ac_HT40/VHT40 mode

Ch.	Frequency (MHz)	Ch.	Frequency (MHz)	Ch.	Frequency (MHz)
42	5 210	58	5 290	106	5 530
				122	5 610

Table 1.2-3. 802.11ac_VHT80 mode

This report shall not be reproduced except in full, without the written approval of KES Co., Ltd.
 The results shown in this test report refer only to the sample(s) tested unless otherwise stated.
 The authenticity of the test report, contact shchoi@kes.co.kr

1.3. Directional antenna gain

Antenna type	Peak Gain (dB i)	Note
Chip antenna	3.50 dB i	2.4 GHz WIFI
Chip antenna	3.94 dB i	BLE, 5 GHz WIFI

1.4. Information about derivative model

The difference between basic and derivative model is bracket and external color, the other circuit diagram and software are fundamentally the same.

- Basic model(SNH-P6415BN) : Metal bracket, White color
- Derivative model(SNH-P6416BN) : Metal bracket, Black color
- Derivative model(SNH-C6415BN) : Metal bracket, White color
- Derivative model(SNH-C6415BNB) : Metal bracket, Black color
- Derivative model(SNH-C6416BN) : Plastic bracket White color
- Derivative model(SNH-C6416BNB) : Plastic bracket Black color

2. Summary of tests

Reference	Parameter	Test results
EN 301 893 4.2.4.1	Transmitter unwanted emissions outside the 5 GHz RLAN bands	Pass
EN 301 893 4.2.5	Receiver spurious emissions	Pass
EN 301 893 4.2.1	Nominal Centre frequencies	Pass
EN 301 893 4.2.2	Nominal Channel Bandwidth and Occupied Channel Bandwidth	Pass
EN 301 893 4.2.3	RF Output Power, TPC and Power density	Pass
EN 301 893 4.2.4.2	Transmitter unwanted emissions within the 5 GHz RLAN bands	Pass
EN 301 893 4.2.6	Dynamic Frequency Selection (DFS)	Pass
EN 301 893 4.2.7	Adaptivity	Pass
EN 301 893 4.2.8	Receiver Blocking	Pass
EN 301 893 4.2.10	Geo-location capability	N/A ^{Note.1}

Note:

1. This device has not support geo-location capability.

3. Application form for testing

3.1. Information as required by EN 301 893 V2.1.1, clause 5.4.1

In accordance with EN 301 893, clause 5.4.1, the following information is provided by the manufacturer.

a) The Nominal Channel Bandwidth(s):

Nominal Channel Bandwidth 1: 20 MHz

Nominal Channel Bandwidth 2: 40 MHz

Nominal Channel Bandwidth 3: 80 MHz

The associated centre frequencies:

For Nominal Channel Bandwidth 1:

for the band 5 150 - 5 350 MHz: 5 180 MHz ~ 5 320 MHz

for the band 5 470 - 5 725 MHz: 5 500 MHz ~ 5 700 MHz

For Nominal Channel Bandwidth 2:

for the band 5 150 - 5 350 MHz: 5 190 MHz ~ 5 310 MHz

for the band 5 470 - 5 725 MHz: 5 510 MHz ~ 5 670 MHz

For Nominal Channel Bandwidth 3:

for the band 5 150 - 5 350 MHz:

for the band 5 470 - 5 725 MHz:

b) For Load Based Equipment that supports multi-channel operation: (N.A)

The LBE equipment supports Option 1 as described in clause 4.2.7.3.2.3

The LBE equipment supports Option 2 as described in clause 4.2.7.3.2.3

The (maximum) number of channels used for multi-channel operation: (N/A)

These channels are adjacent channels:

Yes No

In case of non-adjacent channels, whether or not these channels are in different sub-bands:

Yes No

for LBE equipment implementing option 1 (see clause 4.2.7.3.2.3), the number of channels used for multi-channel operation when performing the test described in clause 5.4.9.3.2.3.1

In case of multi-channel operation, further information defining the channels used for these simultaneous Transmissions may be required.

c) The different transmit operating modes (see clause 5.3.3.2) (tick all that apply):

- Operating mode 1:** Single Antenna Equipment
- a) Equipment with only 1 antenna
 - b) Equipment with diversity antennas but only 1 antenna active at any moment in time
 - c) Smart Antenna Systems with 2 or more antennas, but operating in a (legacy) mode where only 1 antenna is used.
- Operating mode 2:** Smart Antenna Systems - Multiple Antennas without beamforming
- a) Single spatial stream/Standard throughput
 - b) High Throughput (>1 spatial stream) using Nominal Channel Bandwidth 1
 - c) High Throughput (>1 spatial stream) using Nominal Channel Bandwidth 2
- Operating mode 3:** Smart Antenna Systems - Multiple Antennas with beamforming
- a) Single spatial stream/Standard throughput
 - b) High Throughput (>1 spatial stream) using Nominal Channel Bandwidth 1
 - c) High Throughput (>1 spatial stream) using Nominal Channel Bandwidth 2

d) In case of Smart Antenna Systems or multiple antenna systems

- The number of Receive chains: 1
- The number of Transmit chains: 1
- Equal power distribution among the transmit chains: Yes No
- In case of beamforming, the maximum (additional) beamforming gain: **(N/A)**

NOTE : Beamforming gain does not include the basic gain of a single antenna (assembly).

e) TPC feature available:

- Yes
 No

f) For equipment with TPC range: (N/A)

The lowest and highest power level (or lowest and highest e.i.r.p. level in case of integrated antenna equipment), intended antenna assemblies and corresponding operating frequency range for the TPC range (or for each of the TPC ranges if more than one is implemented).

TPC range 1: Applicable Frequency Range:

- 5 150 MHz to 5 350 MHz and 5 470 MHz to 5 725 MHz (Indoor)
Simultaneous transmissions in both sub-bands: Yes No
- 5 470 MHz to 5 725 MHz only (Outdoor only)

Indicate whether the power levels specified are Transmitter Output Power levels or e.i.r.p. levels in case of integrated antenna equipment.

Power levels are specified for: Tx out e.i.r.p

If more than one transmit chain is present (e.g. in the case of smart antenna systems), the power levels below represent the power settings per active transmit chain (and per sub-band in case of multi-channel operation).

Table G.1: Power levels for TPC range 1

	Sub-band (MHz)	Operating mode 1 (dBm)	Operating mode 2 (dBm)	Operating mode 3 (dBm)
Lowest setting (P _{low})	5 150 to 5 350			
	5 470 to 5 725			
Highest setting (P _{high})	5 150 to 5 350			
	5 470 to 5 725			

Beamforming possible: Yes No

Intended Antenna Assemblies:

Table G.2: Intended Antenna Assemblies for TPC range 1

Antenna assembly name	Antenna gain (dBi)	Operating mode	Sub-band (MHz)	Beam forming gain (dB)	e.i.r.p. for P _{low} (dBm)	e.i.r.p. for P _{high} (dBm)
<Antenna 1>		Mode 1	5 150 to 5 350			
			5 470 to 5 725			
		Mode 2	5 150 to 5 350			
			5 470 to 5 725			
		Mode 3	5 150 to 5 350			
			5 470 to 5 725			
<Antenna 2>		Mode 1	5 150 to 5 350			
			5 470 to 5 725			
		Mode 2	5 150 to 5 350			
			5 470 to 5 725			
		Mode 3	5 150 to 5 350			
			5 470 to 5 725			
<Antenna 3>		Mode 1	5 150 to 5 350			
			5 470 to 5 725			
		Mode 2	5 150 to 5 350			
			5 470 to 5 725			
		Mode 3	5 150 to 5 350			
			5 470 to 5 725			

DFS Threshold level:

- at the antenna connector
 in front of the antenna

TPC range 2: Applicable Frequency Range: (N/A)

5 150 MHz to 5 350 MHz and 5 470 MHz to 5 725 MHz (Indoor)

Simultaneous transmissions in both sub-bands: Yes No

5 470 MHz to 5 725 MHz only (Outdoor only)

Indicate whether the power levels specified are Transmitter Output Power levels or e.i.r.p. levels in case of integrated antenna equipment.

Power levels are specified for: Tx out e.i.r.p

If more than 1 transmit chain is present (e.g. in the case of smart antenna systems), the power levels below represent the power settings per active transmit chain (and per sub-band in case of simultaneous transmissions).

Table G.3: Power levels for TPC range 2

	Sub-band (MHz)	Operating mode 1 (dBm)	Operating mode 2 (dBm)	Operating mode 3 (dBm)
Lowest setting (P _{low})	5 150 to 5 350			
	5 470 to 5 725			
Highest setting (P _{high})	5 150 to 5 350			
	5 470 to 5 725			

Beamforming possible: Yes No

Intended Antenna Assemblies:

Table G.4: Intended Antenna Assemblies for TPC range 2

Antenna assembly name	Antenna gain (dBi)	Operating mode	Sub-band (MHz)	Beam forming gain (dB)	e.i.r.p. for P _{low} (dBm)	e.i.r.p. for P _{high} (dBm)
<Antenna 1>		Mode 1	5 150 to 5 350			
			5 470 to 5 725			
		Mode 2	5 150 to 5 350			
			5 470 to 5 725			
		Mode 3	5 150 to 5 350			
			5 470 to 5 725			
<Antenna 2>		Mode 1	5 150 to 5 350			
			5 470 to 5 725			
		Mode 2	5 150 to 5 350			
			5 470 to 5 725			
		Mode 3	5 150 to 5 350			
			5 470 to 5 725			
<Antenna 3>		Mode 1	5 150 to 5 350			
			5 470 to 5 725			
		Mode 2	5 150 to 5 350			
			5 470 to 5 725			
		Mode 3	5 150 to 5 350			
			5 470 to 5 725			

DFS Threshold level: dBm at the antenna connector
 in front of the antenna

g) For equipment without a TPC range:

Power Setting 1: Applicable Frequency Range:

- 5 150 MHz to 5 350 MHz and 5 470 MHz to 5 725 MHz (Indoor)
- Simultaneous transmissions in both sub-bands: Yes No
- 5 470 MHz to 5 725 MHz only (Outdoor only)

Indicate whether the power levels specified are Transmitter Output Power levels or e.i.r.p. levels in case of integrated antenna equipment.

Power levels are specified for: Tx out e.i.r.p

This report shall not be reproduced except in full, without the written approval of KES Co., Ltd.
 The results shown in this test report refer only to the sample(s) tested unless otherwise stated.
 The authenticity of the test report, contact shchoi@kes.co.kr

If more than 1 transmit chain is present (e.g. in the case of smart antenna systems), the power levels below represent the power settings per active transmit chain (and per sub-band in case of simultaneous transmissions)

Table G.5: Maximum Transmitter Output Power for Power Setting 1

Sub-band (MHz)	Operating mode 1 (dBm)	Operating mode 2 (dB m)	Operating mode 3 (dB m)
5 150 to 5 350	5.65	-	-
5 470 to 5 725	6.13	-	-

Beamforming possible: Yes No

Intended Antenna Assemblies:

Table G.6: Intended Antenna Assemblies for Power Setting 1

Antenna assembly name	Antenna gain (dBi)	Operating mode	Sub-band (MHz)	Beam forming gain (dB)	e.i.r.p. (dBm)
<Antenna 1>	Please refer to page 4	Mode 1	5 150 to 5 350	-	11a : 10.71
			5 470 to 5 725	-	11a : 10.99
		Mode 2	5 150 to 5 350	-	11n_HT20 : 10.04 11n_HT40 : 11.08
			5 470 to 5 725	-	11n_HT20 : 9.82 11n_HT40 : 9.19
		Mode 3	5 150 to 5 350	-	11n_VHT20 : 10.79 11n_VHT40 : 11.96 11n_VHT80 : 15.56
			5 470 to 5 725	-	11n_VHT20 : 9.86 11n_VHT40 : 10.17 11n_VHT80 : 13.95
<Antenna 2>	-	Mode 1	5 150 to 5 350	-	-
			5 470 to 5 725	-	-
		Mode 2	5 150 to 5 350	-	-
			5 470 to 5 725	-	-
		Mode 3	5 150 to 5 350	-	-
			5 470 to 5 725	-	-
<Antenna 3>	-	Mode 1	5 150 to 5 350	-	-
			5 470 to 5 725	-	-
		Mode 2	5 150 to 5 350	-	-
			5 470 to 5 725	-	-
		Mode 3	5 150 to 5 350	-	-
			5 470 to 5 725	-	-

DFS Threshold level: -62.30 dBm at the antenna connector
 in front of the antenna



Power Setting 2: Applicable Frequency Range: (N/A)

- 5 150 MHz to 5 350 MHz and 5 470 MHz to 5 725 MHz (Indoor)
 Simultaneous transmissions in both sub-bands: Yes No
- 5 470 MHz to 5 725 MHz only (Outdoor only)

Indicate whether the power levels specified are Transmitter Output Power levels or e.i.r.p. levels in case of integrated antenna equipment.

Power levels are specified for: Tx out e.i.r.p.

If more than one transmit chain is present (e.g. in the case of smart antenna systems), the power levels below represent the power settings per active transmit chain (and per sub-band in case of simultaneous transmissions).

Table G.7: Maximum Transmitter Output Power for Power Setting 2

Sub-band (MHz)	Operating Mode 1 (dBm)	Operating Mode 2 (dB m)	Operating Mode 3 (dB m)
5 150 to 5 350			
5 470 to 5 725			

Beamforming possible: Yes No

Intended Antenna Assemblies:

Table G.8: Intended Antenna Assemblies for Power Setting 2

Antenna assembly name	Antenna gain (dBi)	Operating mode	Sub-band (MHz)	Beam forming gain (dB)	e.i.r.p. (dBm)
<Antenna 1>		Mode 1	5 150 to 5 350		
			5 470 to 5 725		
		Mode 2	5 150 to 5 350		
			5 470 to 5 725		
		Mode 3	5 150 to 5 350		
			5 470 to 5 725		
<Antenna 2>		Mode 1	5 150 to 5 350		
			5 470 to 5 725		
		Mode 2	5 150 to 5 350		
			5 470 to 5 725		
		Mode 3	5 150 to 5 350		
			5 470 to 5 725		
<Antenna 3>		Mode 1	5 150 to 5 350		
			5 470 to 5 725		
		Mode 2	5 150 to 5 350		
			5 470 to 5 725		
		Mode 3	5 150 to 5 350		
			5 470 to 5 725		

DFS Threshold level: dBm at the antenna connector
 in front of the antenna

h) The DFS related operating mode(s) of the equipment (N/A)

- Master
- Slave with radar detection
- Slave without radar detection

If the equipment has more than 1 operating mode, tick all that apply.

i) User access restrictions (please check box below to confirm)

- the equipment is constructed to comply with the requirements contained in clause 4.2.9 in ETSI EN 301 893 V2.1.1



j) For equipment with Off-Channel CAC functionality (N/A)

The equipment has an "Off-Channel CAC" function: Yes No

If yes, specify the "Off-Channel CAC Time"

- For channels outside the 5 600 MHz to 5 650 MHz range: hours
- If applicable, for channels (partially) within the 5 600 MHz to 5 650 MHz range: hours

k) The equipment can operate in ad-hoc mode

- no ad-hoc operation
- ad-hoc operation in the frequency range 5 150 MHz to 5 250 MHz without DFS
- ad-hoc operation with DFS

If more than 1 is applicable, tick all that apply.

l) Operating Frequency Range(s):

- Range 1: 5 150 MHz to 5 350 MHz and 5 470 MHz to 5 725 MHz
- Range 2: 5 470 MHz to 5 725 MHz
- Range 3: 5 150 MHz to 5 250 MHz (ad-hoc without DFS)
- Range 4: other, please specify:

If the equipment has more than one Operating Frequency Range, tick all that apply.

m) The extreme operating temperature and supply voltage range that apply to the equipment:

- 20 °C to +55 °C (Outdoor & Indoor usage)
- 0 °C to +35 °C (Indoor usage only)
- Other: -10 °C to +50 °C

The supply voltages of the stand-alone radio equipment or the supply voltages of the combined (host) equipment or test jig in case of plug-in devices:

- Details provided are for the:
- stand-alone equipment
 - combined (or host) equipment
 - test jig

- Supply Voltage
- AC mains State AC voltage: Minimum: ...Nominal: ... Maximum: ...
 - DC State DC voltage Minimum: 4.5 V Nominal: 5.0 V Maximum: 5.5 V

In case of DC, indicate the type of power source:

- Internal Power Supply
- External Power Supply or AC/DC adapter
- Battery
 - Nickel Cadmium
 - Alkaline
 - Nickel-Metal Hydride
 - Lithium-Ion
 - Lead acid (Vehicle regulated)
 - Other

n) The test sequence/test software used (see also ETSI EN 301 893 (V2.1.1), clause 5.3.1.2):

N/A

o) Type of Equipment

- Stand-alone
- Combined Equipment (Equipment where the radio part is fully integrated within another type of equipment)
- Plug-in radio device (Equipment intended for a variety of host systems)
- Other

p) Adaptivity (Channel Access Mechanism)

- Frame Based Equipment
- Load Based Equipment

q) With regards to Adaptivity for Frame Based Equipment/ (N/A)

- The Frame Based Equipment operates as an Initiating Device
- The Frame Based Equipment operates as an Responding Device
- The Frame Based Equipment can operate as an Initiating Device and as a Responding Device

The Frame Based Equipment has implemented the following Fixed Frame Period(s)

- ms
- ms
- ms

r) With regards to Adaptivity for Load Based Equipment

- The Load Based Equipment operates as a Supervising Device
- The Load Based Equipment operates as a Supervised Device
- The Load Based Equipment can operate as a Supervising and as a Supervised Device
- The Load Based Equipment makes use of note 1 in table 7 or note 1 in table 8 of ETSI EN 301 893 V2.1.1
- The Load Based Equipment, when operating as a Supervising Device, makes use of note 2 in Table 7 of ETSI EN 301 893 V2.1.1

The Priority Classes implemented by the Load Based Equipment

- When operating as a Supervising Device
 - Priority Class 4 (Highest priority)
 - Priority Class 3
 - Priority Class 2
 - Priority Class 1 (Lowest priority)
- When operating as a Supervised Device
 - Priority Class 4 (Highest priority)
 - Priority Class 3
 - Priority Class 2
 - Priority Class 1 (Lowest priority)

With regard to Energy Detection Threshold, the Load Based Equipment has implemented either option 1 of clause 4.2.7.3.2.5 of ETSI EN 301 893 V2.1.1 or option 2 of clause 4.2.7.3.2.5 of ETSI EN 301 893 V2.1.1:

Option 1

Option 2

Specify which protocol has been implemented: IEEE 802.11™ Other:

s) **The equipment supports a geo-location capability as defined in clause 4.2.10 of ETSI EN 301 893 v2.1.1 :**

Yes No

t) **The minimum performance criteria (see ETSI EN 301 893 V2.1.1, clause 4.2.8.3) that corresponds to the intended use of the equipment:**

N/A

q) **The theoretical maximum radio performance of the equipment (e.g. maximum throughput) (see ETSI EN 301 893 V2.1.1, clause 5.4.9.3.1):**

N/A



3.2 Additional information provided by the manufacturer

Modulation: Can the transmitter operate un-modulated? Yes No

Duty Cycle: The transmitter is intended for :

- Continuous duty
- Intermittent duty
- Continuous operation possible for testing purposes

About the UUT:

- The equipment submitted are representative production models.
- If not, the equipment submitted are pre-production models?
- If pre-production equipment are submitted, the final production equipment will be identical in all respects with the equipment tested.
- If not, supply full details:

- The equipment submitted is CE marked:
- The CE marking does include the Class-II identifier (Alert Sign).
- The CE marking does include a 4 digit number referring to the Notified Body involved.

3.3 List of ancillary and/or support equipment provided by the manufacturer

- Spare batteries (e.g. for portable equipment):
- Battery charging device
- External Power Supply or AC/DC adapter
- Test Jig or interface box
- RF test fixture (for equipment with integrated antennas)
- Host System Manufacturer:
- Model #:
- Model name:
- Combined equipment Manufacturer:
- Model #:
- Model name:
- User manual
- Technical documentation (Handbook and circuit diagrams)

This report shall not be reproduced except in full, without the written approval of KES Co., Ltd.
 The results shown in this test report refer only to the sample(s) tested unless otherwise stated.
 The authenticity of the test report, contact shchoi@kes.co.kr

4. Test results

4.1. Transmitter unwanted emissions outside the 5 GHz RLAN bands

Measurement Condition

Ambient temperature : 22.2 °C
Relative humidity : 39.5 % R.H.

Test procedure

EN 301 893 clause 5.4.5.2

5.4.5.2.1.1 Pre-scan

Step 2 :

The unwanted emissions over the range 30 MHz to 1 000 MHz shall be identified.

Spectrum analyser settings:

1. RBW : 100 kHz
2. VBW : 300 kHz
3. Detector mode : Peak
4. Trace mode : Max hold
5. Sweep points : 9 700

For spectrum analysers not supporting this number of sweep points, the frequency band may be segmented. For spectrum analysers capable of supporting twice this number of sweep points, the frequency adjustment in clause 5.4.5.2.1.2 (step 1, last bullet) may be omitted.

6. Sweep time : For non-continuous transmissions (duty cycle less than 100 %), the sweep time shall be sufficiently long, such that for each 100 kHz frequency step, the measurement time is greater than two transmissions of the UUT.

Step 3 :

The unwanted emissions over the range 1 GHz to 26 GHz shall be identified.

Spectrum analyser settings:

1. RBW : 1 MHz
2. VBW : 3 MHz
3. Detector mode : Peak
4. Trace mode : Max hold
5. Sweep points : 25 000

For spectrum analysers not supporting this number of sweep points, the frequency band may be segmented. For spectrum analysers capable of supporting twice this number of sweep points, the frequency adjustment in clause 5.4.5.2.1.2 (step 1, last bullet) may be omitted.

6. Sweep time : For non-continuous transmissions (duty cycle less than 100 %), the sweep time shall be sufficiently long, such that for each 1 MHz frequency step, the measurement time is greater than two transmissions of the UUT.

5.4.5.2.1.2 Measurement of the emissions identified during the pre-scan

Step 1:

The level of the emissions shall be measured in the time domain, using the following spectrum analyser settings:

1. Centre frequency : Frequency of emission identified during the pre-scan
2. RBW : 100 kHz (< 1 GHz) / 1 MHz (>1 GHz)
3. VBW : 300 kHz (< 1 GHz) / 3 MHz (>1 GHz)
4. Frequency span : 0 Hz
5. Sweep mode : Single sweep
6. Sweep time : Suitable to capture one transmission burst. Additional measurements may be needed to identify the length of the transmission burst. In case of continuous signals, the Sweep Time shall be set to 30 ms
7. Sweep point : Sweep time [μ s] / 1 μ s with a maximum of 30 000
8. Trigger : Video (Burst signals) or Manual (continuous signals)
9. Detector : RMS
10. Trace mode : Clear/Write



Test results

Mode: 802.11a
 Distance of measurement: 3 meter

Lowest frequency (5 180 MHz)				Highest frequency (5 320 MHz)			
Frequency(MHz)	Ant Pol	Bandwidth(kHz)	Level(dBm)	Frequency(MHz)	Ant Pol	Bandwidth(kHz)	Level(dBm)
10 360	H	1 000	-60.03	10 640	H	1 000	-60.58
10 360	V	1 000	-61.94	10 640	V	1 000	-61.17

Mode: 802.11a
 Distance of measurement: 3 meter

Lowest frequency (5 500 MHz)				Highest frequency (5 700 MHz)			
Frequency(MHz)	Ant Pol	Bandwidth(kHz)	Level(dBm)	Frequency(MHz)	Ant Pol	Bandwidth(kHz)	Level(dBm)
11 000	H	1 000	-60.25	11 400	H	1 000	-60.23
11 000	V	1 000	-61.09	11 400	V	1 000	-61.56

Mode: 802.11n(HT20)
 Distance of measurement: 3 meter

Lowest frequency (5 180 MHz)				Highest frequency (5 320 MHz)			
Frequency(MHz)	Ant Pol	Bandwidth(kHz)	Level(dBm)	Frequency(MHz)	Ant Pol	Bandwidth(kHz)	Level(dBm)
10 360	H	1 000	-60.30	10 640	H	1 000	-60.50
10 360	V	1 000	-61.85	10 640	V	1 000	-62.28

Mode: 802.11n(HT20)
 Distance of measurement: 3 meter

Lowest frequency (5 500 MHz)				Highest frequency (5 700 MHz)			
Frequency(MHz)	Ant Pol	Bandwidth(kHz)	Level(dBm)	Frequency(MHz)	Ant Pol	Bandwidth(kHz)	Level(dBm)
11 000	H	1 000	-59.40	11 400	H	1 000	-60.28
11 000	V	1 000	-61.50	11 400	V	1 000	-61.23

This report shall not be reproduced except in full, without the written approval of KES Co., Ltd.
 The results shown in this test report refer only to the sample(s) tested unless otherwise stated.
 The authenticity of the test report, contact shchoi@kes.co.kr



Mode: 802.11ac(VHT20)
Distance of measurement: 3 meter

Lowest frequency (5 180 MHz)				Highest frequency (5 320 MHz)			
Frequency(MHz)	Ant Pol	Bandwidth(kHz)	Level(dBm)	Frequency(MHz)	Ant Pol	Bandwidth(kHz)	Level(dBm)
10 360	H	1 000	-60.05	10 640	H	1 000	-60.17
10 360	V	1 000	-61.84	10 640	V	1 000	-61.01

Mode: 802.11ac(VHT20)
Distance of measurement: 3 meter

Lowest frequency (5 500 MHz)				Highest frequency (5 700 MHz)			
Frequency(MHz)	Ant Pol	Bandwidth(kHz)	Level(dBm)	Frequency(MHz)	Ant Pol	Bandwidth(kHz)	Level(dBm)
11 000	H	1 000	-60.84	11 400	H	1 000	-60.34
11 000	V	1 000	-61.05	11 400	V	1 000	-61.30



Mode: 802.11n(HT40)
 Distance of measurement: 3 meter

Lowest frequency (5 190 MHz)				Highest frequency (5 310 MHz)			
Frequency(MHz)	Ant Pol	Bandwidth(kHz)	Level(dBm)	Frequency(MHz)	Ant Pol	Bandwidth(kHz)	Level(dBm)
10 380	H	1 000	-60.31	10 620	H	1 000	-60.27
10 380	V	1 000	-61.34	10 620	V	1 000	-61.80

Mode: 802.11n(HT40)
 Distance of measurement: 3 meter

Lowest frequency (5 510 MHz)				Highest frequency (5 670 MHz)			
Frequency(MHz)	Ant Pol	Bandwidth(kHz)	Level(dBm)	Frequency(MHz)	Ant Pol	Bandwidth(kHz)	Level(dBm)
11 020	H	1 000	-60.36	11 340	H	1 000	-60.93
11 020	V	1 000	-61.14	11 340	V	1 000	-61.28

Mode: 802.11ac(VHT40)
 Distance of measurement: 3 meter

Lowest frequency (5 190 MHz)				Highest frequency (5 310 MHz)			
Frequency(MHz)	Ant Pol	Bandwidth(kHz)	Level(dBm)	Frequency(MHz)	Ant Pol	Bandwidth(kHz)	Level(dBm)
10 380	H	1 000	-60.01	10 620	H	1 000	-60.10
10 380	V	1 000	-61.32	10 620	V	1 000	-61.72

Mode: 802.11ac(VHT40)
 Distance of measurement: 3 meter

Lowest frequency (5 510 MHz)				Highest frequency (5 670 MHz)			
Frequency(MHz)	Ant Pol	Bandwidth(kHz)	Level(dBm)	Frequency(MHz)	Ant Pol	Bandwidth(kHz)	Level(dBm)
11 020	H	1 000	-60.01	11 340	H	1 000	-60.84
11 020	V	1 000	-61.32	11 340	V	1 000	-61.09

This report shall not be reproduced except in full, without the written approval of KES Co., Ltd.
 The results shown in this test report refer only to the sample(s) tested unless otherwise stated.
 The authenticity of the test report, contact shchoi@kes.co.kr



Mode: 802.11ac(VHT80)
Distance of measurement: 3 meter

Lowest frequency (5 210 MHz)				Highest frequency (5 290 MHz)			
Frequency(MHz)	Ant Pol	Bandwidth(kHz)	Level(dBm)	Frequency(MHz)	Ant Pol	Bandwidth(kHz)	Level(dBm)
10 420	H	1 000	-60.84	10 580	H	1 000	-60.43
10 420	V	1 000	-61.34	10 580	V	1 000	-61.22

Mode: 802.11ac(VHT80)
Distance of measurement: 3 meter

Lowest frequency (5 530 MHz)				Highest frequency (5 610 MHz)			
Frequency(MHz)	Ant Pol	Bandwidth(kHz)	Level(dBm)	Frequency(MHz)	Ant Pol	Bandwidth(kHz)	Level(dBm)
11 060	H	1 000	-60.12	11 220	H	1 000	-60.09
11 060	V	1 000	-61.49	11 220	V	1 000	-61.88

Limit (Clause 4.2.4.1.2)

The level of transmitter unwanted emissions outside the 5 GHz RLAN bands shall not exceed the limits given in table 4. In case of equipment with antenna connectors, these limits apply to emissions at the antenna port (conducted). For emissions radiated by the cabinet or emissions radiated by integral antenna equipment (without antenna connectors), these limits are e.r.p. for emissions up to 1 GHz and e.i.r.p. for emissions above 1 GHz.

Table 4: Transmitter unwanted emission limits outside the 5 GHz RLAN bands

Frequency Range	Maximum power,	Bandwidth
30 MHz to 47 MHz	-36 dBm	100 kHz
47 MHz to 74 MHz	-54 dBm	100 kHz
74 MHz to 87.5 MHz	-36 dBm	100 kHz
87.5 MHz to 118 MHz	-54 dBm	100 kHz
118 MHz to 174 MHz	-36 dBm	100 kHz
174 MHz to 230 MHz	-54 dBm	100 kHz
230 MHz to 470 MHz	-36 dBm	100 kHz
470 MHz to 862 MHz	-54 dBm	100 kHz
862 MHz to 1 GHz	-36 dBm	100 kHz
1 GHz to 5.15 GHz	-30 dBm	1 MHz
5.35 GHz to 5.47 GHz	-30 dBm	1 MHz
5.725 GHz to 26 GHz	-30 dBm	1 MHz

This report shall not be reproduced except in full, without the written approval of KES Co., Ltd.
 The results shown in this test report refer only to the sample(s) tested unless otherwise stated.
 The authenticity of the test report, contact shchoi@kes.co.kr

4.2. Receiver spurious emissions

Measurement Condition

Ambient temperature : 22.2 °C
Relative humidity : 39.5 % R.H.

Test procedure

EN 301 893 clause 5.4.7.2

5.4.7.2.1 Pre-scan

Step 2:

The emissions shall be measured over the range 30 MHz to 1 000 MHz.

Spectrum analyser settings:

1. RBW : 100 kHz
2. VBW : 300 kHz
3. Detector mode : Peak
4. Trace mode : Max hold
5. Sweep points : 9 700

For spectrum analysers not supporting this number of sweep points, the frequency band may be segmented. For spectrum analysers capable of supporting twice this number of sweep points, the frequency adjustment in clause 5.4.7.2.1.2 (step 1, last bullet) may be omitted.

6. Sweep time : Auto

Wait for the trace to stabilize. Any emissions identified that have a margin of less than 6dB with respect to the limits given in clause 4.2.5.2, table 5, shall be individually measured using the procedure in clause 5.4.7.2.1.2 and compared to the limits given in clause 4.2.5.2, table 5.

Step 3:

The emissions shall now be measured over the range 1 GHz to 26 GHz.

Spectrum analyser settings:

1. RBW : 1 MHz
2. VBW : 3 MHz
3. Detector mode : Peak
4. Trace mode : Max hold
5. Sweep points : 25 000

For spectrum analysers not supporting this high number of sweep points, the frequency band may need to be segmented. For spectrum analysers capable of supporting twice this number of sweep points, the frequency adjustment in clause 5.4.7.2.1.2 (step 1, last bullet) may be omitted.

6. Sweep time : Auto

Wait for the trace to stabilize. Any emissions identified that have a margin of less than 6dB with respect to the limits given in clause 4.2.5.2, table 5, shall be individually measured using the procedure in clause 5.4.7.2.1.2 and compared to the limits given in clause 4.2.5.2, table 5.

5.4.7.2.1.2 Measurement of the emissions identified during the pre-scan

Step 1:

The level of the emissions shall be measured using the following spectrum analyser settings:

1. Measurement mode : Time domain power
2. Centre frequency : Frequency of the emission identified during the pre-scan
3. RBW : 100 kHz (emissions < 1 GHz) / 1 MHz (emissions >1 GHz)
4. VBW : 300 kHz (emissions < 1 GHz) / 3 MHz (emissions >1 GHz)
5. Frequency span : Zero span
6. Sweep mode : Single sweep
7. Sweep time : 30 ms
8. Sweep points : $\geq 30\ 000$
9. Trigger : Video (for burst signals) or Manual (for continuous signals)
10. Detector : RMS



Test results

Mode: 802.11a
 Distance of measurement: 3 meter

Lowest frequency (5 180 MHz)				Highest frequency (5 320 MHz)			
Frequency(MHz)	Ant Pol	Bandwidth(kHz)	Level(dBm)	Frequency(MHz)	Ant Pol	Bandwidth(kHz)	Level(dBm)
Emission levels are not reported much lower than the limits by over 20 dB							

Mode: 802.11a
 Distance of measurement: 3 meter

Lowest frequency (5 500 MHz)				Highest frequency (5 700 MHz)			
Frequency(MHz)	Ant Pol	Bandwidth(kHz)	Level(dBm)	Frequency(MHz)	Ant Pol	Bandwidth(kHz)	Level(dBm)
Emission levels are not reported much lower than the limits by over 20 dB							

Mode: 802.11n(HT20)
 Distance of measurement: 3 meter

Lowest frequency (5 180 MHz)				Highest frequency (5 320 MHz)			
Frequency(MHz)	Ant Pol	Bandwidth(kHz)	Level(dBm)	Frequency(MHz)	Ant Pol	Bandwidth(kHz)	Level(dBm)
Emission levels are not reported much lower than the limits by over 20 dB							

Mode: 802.11n(HT20)
 Distance of measurement: 3 meter

Lowest frequency (5 500 MHz)				Highest frequency (5 700 MHz)			
Frequency(MHz)	Ant Pol	Bandwidth(kHz)	Level(dBm)	Frequency(MHz)	Ant Pol	Bandwidth(kHz)	Level(dBm)
Emission levels are not reported much lower than the limits by over 20 dB							

This report shall not be reproduced except in full, without the written approval of KES Co., Ltd.
 The results shown in this test report refer only to the sample(s) tested unless otherwise stated.
 The authenticity of the test report, contact shchoi@kes.co.kr



Mode: 802.11ac(VHT20)
Distance of measurement: 3 meter

Lowest frequency (5 180 MHz)				Highest frequency (5 320 MHz)			
Frequency(MHz)	Ant Pol	Bandwidth(kHz)	Level(dBm)	Frequency(MHz)	Ant Pol	Bandwidth(kHz)	Level(dBm)
Emission levels are not reported much lower than the limits by over 20 dB							

Mode: 802.11ac(VHT20)
Distance of measurement: 3 meter

Lowest frequency (5 500 MHz)				Highest frequency (5 700 MHz)			
Frequency(MHz)	Ant Pol	Bandwidth(kHz)	Level(dBm)	Frequency(MHz)	Ant Pol	Bandwidth(kHz)	Level(dBm)
Emission levels are not reported much lower than the limits by over 20 dB							



KES Co., Ltd.

3701, 40, Simin-daero 365beon-gil,
Dongan-gu, Anyang-si, Gyeonggi-do, 14057, Korea
Tel: +82-31-425-6200 / Fax: +82-31-424-0450
www.kes.co.kr

Report No.:
KES-RF-18T0119
Page (34) of (107)

Mode: 802.11n(HT40)
Distance of measurement: 3 meter

Lowest frequency (5 190 MHz)				Highest frequency (5 310 MHz)			
Frequency(MHz)	Ant Pol	Bandwidth(kHz)	Level(dBm)	Frequency(MHz)	Ant Pol	Bandwidth(kHz)	Level(dBm)
Emission levels are not reported much lower than the limits by over 20 dB							

Mode: 802.11n(HT40)
Distance of measurement: 3 meter

Lowest frequency (5 510 MHz)				Highest frequency (5 670 MHz)			
Frequency(MHz)	Ant Pol	Bandwidth(kHz)	Level(dBm)	Frequency(MHz)	Ant Pol	Bandwidth(kHz)	Level(dBm)
Emission levels are not reported much lower than the limits by over 20 dB							

Mode: 802.11ac(VHT40)
Distance of measurement: 3 meter

Lowest frequency (5 190 MHz)				Highest frequency (5 310 MHz)			
Frequency(MHz)	Ant Pol	Bandwidth(kHz)	Level(dBm)	Frequency(MHz)	Ant Pol	Bandwidth(kHz)	Level(dBm)
Emission levels are not reported much lower than the limits by over 20 dB							

Mode: 802.11ac(VHT40)
Distance of measurement: 3 meter

Lowest frequency (5 510 MHz)				Highest frequency (5 670 MHz)			
Frequency(MHz)	Ant Pol	Bandwidth(kHz)	Level(dBm)	Frequency(MHz)	Ant Pol	Bandwidth(kHz)	Level(dBm)
Emission levels are not reported much lower than the limits by over 20 dB							

This report shall not be reproduced except in full, without the written approval of KES Co., Ltd.
The results shown in this test report refer only to the sample(s) tested unless otherwise stated.
The authenticity of the test report, contact shchoi@kes.co.kr



Mode: 802.11ac(VHT80)
Distance of measurement: 3 meter

Lowest frequency (5 210 MHz)				Highest frequency (5 290 MHz)			
Frequency(MHz)	Ant Pol	Bandwidth(kHz)	Level(dBm)	Frequency(MHz)	Ant Pol	Bandwidth(kHz)	Level(dBm)
Emission levels are not reported much lower than the limits by over 20 dB							

Mode: 802.11ac(VHT80)
Distance of measurement: 3 meter

Lowest frequency (5 530 MHz)				Highest frequency (5 610 MHz)			
Frequency(MHz)	Ant Pol	Bandwidth(kHz)	Level(dBm)	Frequency(MHz)	Ant Pol	Bandwidth(kHz)	Level(dBm)
Emission levels are not reported much lower than the limits by over 20 dB							

This report shall not be reproduced except in full, without the written approval of KES Co., Ltd.
The results shown in this test report refer only to the sample(s) tested unless otherwise stated.
The authenticity of the test report, contact shchoi@kes.co.kr

Limit (Clause 4.2.5.2)

The spurious emissions of the receiver shall not exceed the limits given in table 5.

In case of equipment with antenna connectors, these limits apply to emissions at the antenna port (conducted).

For emissions radiated by the cabinet or emissions radiated by integral antenna equipment (without antenna connectors), these limits are e.r.p. for emissions up to 1 GHz and e.i.r.p. for emissions above 1 GHz.

Table 5: Spurious radiated emission limits

Frequency Range	Maximum power	Measurement bandwidth
30 MHz to 1 GHz	-57 dBm	100 kHz
1 GHz to 26 GHz	-47 dBm	1 MHz

4.3. Centre frequencies

Measurement Condition

Ambient temperature : 24.0 °C
Relative humidity : 40.2 % R.H.

Test procedure

EN 301 893 clause 5.4.2.2 – 5.4.2.2.1.1 or 5.4.2.2.1.2
Used test method is 5.4.2.2.1.1

5.4.2.2.1.1 Equipment operating without modulation

This test method requires that the UUT can be operated in an unmodulated test mode.
The UUT shall be connected to a suitable frequency measuring device (e.g. a frequency counter or a spectrum analyser) and operated in an unmodulated mode.
The result shall be recorded.

5.4.2.2.1 Equipment operating with modulation

This method is an alternative to the above method in case the UUT cannot be operated in an un-modulated mode.
The UUT shall be connected to spectrum analyser.
Max Hold shall be selected and the centre frequency adjusted to that of the UUT.

The peak value of the power envelope shall be measured and noted. The span shall be reduced and the marker moved in a positive frequency increment until the upper, (relative to the centre frequency), -10 dBc point is reached. This value shall be noted as f1.

The marker shall then be moved in a negative frequency increment until the lower, (relative to the centre frequency), -10 dBc point is reached. This value shall be noted as f2.

The centre frequency is calculated as $(f1 + f2) / 2$.

Test results

Mode: 802.11a

Test Temp.(°C)	Voltage(V _{a.c.})	Carrier frequencies	
		Low Frequency (5 180 MHz)	High Frequency (5 320 MHz)
T min = -10	V min = 207	5 180.005 964	5 319.972 215
		1.15 ppm	-5.22 ppm
	V max = 240	5 180.004 841	5 319.973 584
		0.93 ppm	-4.97 ppm
T nom = 24	V nom = 230	5 180.006 894	5 319.972 486
		1.33 ppm	-5.17 ppm
T max = 50	V min = 207	5 180.007 452	5 319.973 241
		1.44 ppm	-5.03 ppm
	V max = 240	5 180.007 852	5 319.971 457
		1.52 ppm	-5.37 ppm

Mode: 802.11n(HT20)

Test Temp.(°C)	Voltage(V _{d.c.})	Carrier frequencies	
		Low Frequency (5 180 MHz)	High Frequency (5 320 MHz)
T min = -10	V min = 207	5 180.007 485	5 319.978 561
		1.44 ppm	-4.03 ppm
	V max = 240	5 180.009 541	5 319.975 452
		1.84 ppm	-4.61 ppm
T nom = 24	V nom = 230	5 180.004 181	5 319.978 994
		0.81 ppm	-3.95 ppm
T max = 50	V min = 207	5 180.009 452	5 319.976 484
		1.82 ppm	-4.42 ppm
	V max = 240	5 180.007 979	5 319.984 238
		1.54 ppm	-2.96 ppm

This report shall not be reproduced except in full, without the written approval of KES Co., Ltd.
 The results shown in this test report refer only to the sample(s) tested unless otherwise stated.
 The authenticity of the test report, contact shchoi@kes.co.kr

Mode: 802.11ac(VHT20)

Test Temp.(°C)	Voltage(V _{d.c.})	Carrier frequencies	
		Low Frequency (5 180 MHz)	High Frequency (5 320 MHz)
T min = -10	V min = 207	5 180.009 582	5 319.984 559
		1.85 ppm	-2.90 ppm
	V max = 240	5 180.010 294	5 319.982 576
		1.99 ppm	-3.28 ppm
T nom = 24	V nom = 230	5 180.008 942	5 319.974 294
		1.73 ppm	-4.83 ppm
T max = 50	V min = 207	5 180.006 974	5 319.983 117
		1.35 ppm	-3.17 ppm
	V max = 240	5 180.007 591	5 319.984 182
		1.47 ppm	-2.97 ppm

Mode: 802.11n(HT40)

Test Temp.(°C)	Voltage(V _{d.c.})	Carrier frequencies	
		Low Frequency (5 190 MHz)	High Frequency (5 310 MHz)
T min = -10	V min = 207	5 189.974 527	5 309.985 176
		-4.91 ppm	-2.79 ppm
	V max = 240	5 189.972 483	5 309.984 179
		-5.30 ppm	-2.98 ppm
T nom = 24	V nom = 230	5 189.954 841	5 309.981 235
		-8.70 ppm	-3.53 ppm
T max = 50	V min = 207	5 189.969 245	5 309.984 910
		-5.93 ppm	-2.84 ppm
	V max = 240	5 189.974 460	5 309.982 641
		-4.92 ppm	-3.27 ppm

This report shall not be reproduced except in full, without the written approval of KES Co., Ltd.
 The results shown in this test report refer only to the sample(s) tested unless otherwise stated.
 The authenticity of the test report, contact shchoi@kes.co.kr

Mode: 802.11ac(VHT40)

Test Temp.(°C)	Voltage(V _{d.c.})	Carrier frequencies	
		Low Frequency (5 190 MHz)	High Frequency (5 310 MHz)
T min = -10	V min = 207	5 189.985 137 -2.86 ppm	5 309.984 942 -2.84 ppm
	V max = 240	5 189.981 158 -3.63 ppm	5 309.984 618 -2.90 ppm
T nom = 24	V nom = 230	5 189.982 394 -3.39 ppm	5 309.982 593 -3.28 ppm
		5 189.984 942 -2.90 ppm	5 309.989 471 -1.98 ppm
T max = 50	V min = 207	5 189.982 475 -3.38 ppm	5 309.989 842 -1.91 ppm
	V max = 240		

Mode: 802.11ac(VHT80)

Test Temp.(°C)	Voltage(V _{d.c.})	Carrier frequencies	
		Low Frequency (5 210 MHz)	High Frequency (5 290 MHz)
T min = -10	V min = 207	5 209.987 412 -2.42 ppm	5 290.004 529 0.86 ppm
	V max = 240	5 209.984 538 -2.97 ppm	5 290.008 744 1.65 ppm
T nom = 24	V nom = 230	5 209.984 944 -2.89 ppm	5 290.008 894 1.68 ppm
		5 209.984 487 -2.98 ppm	5 290.009 949 1.88 ppm
T max = 50	V min = 207	5 209.985 941 -2.70 ppm	5 290.010 291 1.95 ppm
	V max = 240		

This report shall not be reproduced except in full, without the written approval of KES Co., Ltd.
 The results shown in this test report refer only to the sample(s) tested unless otherwise stated.
 The authenticity of the test report, contact shchoi@kes.co.kr

Mode: 802.11a

Test Temp.(°C)	Voltage(V _{d.c.})	Carrier frequencies	
		Low Frequency (5 500 MHz)	High Frequency (5 700 MHz)
T min = -10	V min = 207	5 500.004 841	5 699.974 169
		0.88 ppm	-4.53 ppm
	V max = 240	5 500.005 741	5 699.97 5821
		1.04 ppm	-4.24 ppm
T nom = 24	V nom = 230	5 500.009 836	5 699.978 941
		1.79 ppm	-3.69 ppm
T max = 50	V min = 207	5 500.008 743	5 699.979 017
		1.59 ppm	-3.68 ppm
	V max = 240	5 500.008 714	5 699.978 024
		1.58 ppm	-3.86 ppm

Mode: 802.11n(HT20)

Test Temp.(°C)	Voltage(V _{d.c.})	Carrier frequencies	
		Low Frequency (5 500 MHz)	High Frequency (5 700 MHz)
T min = -10	V min = 207	5500.019842	5 699.974 841
		3.61 ppm	-4.41 ppm
	V max = 240	5500.018645	5 699.975 878
		3.39 ppm	-4.23 ppm
T nom = 24	V nom = 230	5500.015043	5 699.978 744
		2.74 ppm	-3.72 ppm
T max = 50	V min = 207	5500.014369	5 699.979 181
		2.61 ppm	-3.65 ppm
	V max = 240	5500.012375	5 699.978 297
		2.25 ppm	-3.81 ppm

This report shall not be reproduced except in full, without the written approval of KES Co., Ltd.
 The results shown in this test report refer only to the sample(s) tested unless otherwise stated.
 The authenticity of the test report, contact shchoi@kes.co.kr

Mode: 802.11ac(VHT20)

Test Temp.(°C)	Voltage(V _{d.c.})	Carrier frequencies	
		Low Frequency (5 500 MHz)	High Frequency (5 700 MHz)
T min = -10	V min = 207	5 500.020 484	5 699.974 184
		3.72 ppm	-4.53 ppm
	V max = 240	5 500.020 245	5 699.971 842
		3.68 ppm	-4.94 ppm
T nom = 24	V nom = 230	5 500.020 543	5 699.970 174
		3.74 ppm	-5.23 ppm
T max = 50	V min = 207	5 500.020 169	5 699.978 456
		3.67 ppm	-3.78 ppm
	V max = 240	5 500.020 475	5 699.978 940
		3.72 ppm	-3.69 ppm

Mode: 802.11n(HT40)

Test Temp.(°C)	Voltage(V _{d.c.})	Carrier frequencies	
		Low Frequency (5 510 MHz)	High Frequency (5 670 MHz)
T min = -10	V min = 207	5 510.014 125	5 669.972 546
		2.56 ppm	-4.84 ppm
	V max = 240	5 510.015 958	5 669.971 814
		2.90 ppm	-4.97 ppm
T nom = 24	V nom = 230	5 510.015 992	5 669.971 874
		2.90 ppm	-4.96 ppm
T max = 50	V min = 207	5 510.016 238	5 669.974 582
		2.95 ppm	-4.48 ppm
	V max = 240	5 510.018 943	5 669.971 703
		3.44 ppm	-4.99 ppm

This report shall not be reproduced except in full, without the written approval of KES Co., Ltd.
 The results shown in this test report refer only to the sample(s) tested unless otherwise stated.
 The authenticity of the test report, contact shchoi@kes.co.kr

Mode: 802.11ac(VHT40)

Test Temp.(°C)	Voltage(V _{d.c.})	Carrier frequencies	
		Low Frequency (5 510 MHz)	High Frequency (5 670 MHz)
T min = -10	V min = 207	5 510.015 984	5 669.973 235
		2.90 ppm	-4.72 ppm
	V max = 240	5 510.016 753	5 669.972 878
		3.04 ppm	-4.78 ppm
T nom = 24	V nom = 230	5 510.016 987	5 669.971 365
		3.08 ppm	-5.05 ppm
T max = 50	V min = 207	5 510.017 894	5 669.975 842
		3.25 ppm	-4.26 ppm
	V max = 240	5 510.017 664	5 669.971 862
		3.21 ppm	-4.96

Mode: 802.11ac(VHT80)

Test Temp.(°C)	Voltage(V _{d.c.})	Carrier frequencies	
		Low Frequency (5 530 MHz)	High Frequency (5 610 MHz)
T min = -10	V min = 207	5 530.017 891	5 610.029 147
		3.24 ppm	5.20 ppm
	V max = 240	5 530.018 963	5 610.028 713
		3.43 ppm	5.12 ppm
T nom = 24	V nom = 230	5 530.019 698	5 610.024 874
		3.56 ppm	4.43 ppm
T max = 50	V min = 207	5 530.020 184	5 610.021 888
		3.65 ppm	3.90
	V max = 240	5 530.029 642	5 610.019 774
		5.36 ppm	3.52 ppm

This report shall not be reproduced except in full, without the written approval of KES Co., Ltd.
 The results shown in this test report refer only to the sample(s) tested unless otherwise stated.
 The authenticity of the test report, contact shchoi@kes.co.kr

Limit (Clause 4.2.1.3)

The *Nominal Centre Frequencies* (f_c) for a *Nominal Channel Bandwidth* of 20 MHz are defined by equation(1).
See also figure 3.

$$f_c = 5\,160 + (g \times 20) \text{ MHz, where } 0 \leq g \leq 9 \text{ or } 16 \leq g \leq 27 \text{ and where } g \text{ shall be an integer. (1)}$$

A maximum offset of the *Nominal Centre Frequency* of ± 200 kHz is permitted. Where the manufacturer decides to make use of this frequency offset, the manufacturer shall declare the actual centre frequencies used by the equipment.
See clause 5.4.1, item a).

The actual centre frequency for any given channel declared by the manufacturer shall be maintained within the range $f_c \pm 20$ ppm.

Equipment may have simultaneous transmissions on more than one *Operating Channel* with a *Nominal Channel Bandwidth* of 20 MHz

4.4. Nominal channel bandwidth and Occupied channel bandwidth

Measurement Condition

Ambient temperature : 24 °C
Relative humidity : 40.2 % R.H.

Test procedure

EN 301 893 clause 5.4.3.2

The measurement procedure shall be as follows:

Step 1:

Connect the UUT to the spectrum analyser and use the following settings:

1. Centre frequency : The centre frequency of the channel under test
2. RBW : 100 kHz
3. VBW : 300 kHz
4. Frequency span : $2 \times$ Nominal Bandwidth (e.g. 40 MHz for a 20 MHz channel)
5. Sweep time : >1 s; for larger Nominal Bandwidths, the sweep time may be increased until a value where the Sweep time has no impact on the RMS value of the signal
6. Detector mode : RMS
7. Trace mode : Max hold

Step 2 :

- Wait for the trace to stabilize.

Step 3 :

- Make sure that the power envelope is sufficiently above the noise floor of the analyser to avoid the noise signals left and right from the power envelope being taken into account by this measurement.
- Use the 99 % bandwidth function of the spectrum analyser to measure the Occupied Channel Bandwidth of the UUT.
This value shall be recorded.
- The measurement described in step 1 to step 3 above shall be repeated in case of simultaneous transmissions in Non-adjacent channels.

Test results

Mode: 802.11a

Test item	Low Frequency (5 180 MHz)	High Frequency (5 320 MHz)
99 % Bandwidth (MHz)	16.43	16.42

Mode: 802.11n(HT20)

Test item	Low Frequency (5 180 MHz)	High Frequency (5 320 MHz)
99 % Bandwidth (MHz)	17.62	17.63

Mode: 802.11ac(VHT20)

Test item	Low Frequency (5 180 MHz)	High Frequency (5 320 MHz)
99 % Bandwidth (MHz)	17.62	17.62

Mode: 802.11n(HT40)

Test item	Low Frequency (5 190 MHz)	High Frequency (5 310 MHz)
99 % Bandwidth (MHz)	36.10	36.17

Mode: 802.11ac(VHT40)

Test item	Low Frequency (5 190 MHz)	High Frequency (5 310 MHz)
99 % Bandwidth (MHz)	36.20	36.21

Mode: 802.11ac(VHT80)

Test item	Low Frequency (5 210 MHz)	High Frequency (5 290 MHz)
99 % Bandwidth (MHz)	75.03	75.02

This report shall not be reproduced except in full, without the written approval of KES Co., Ltd.
 The results shown in this test report refer only to the sample(s) tested unless otherwise stated.
 The authenticity of the test report, contact shchoi@kes.co.kr



KES Co., Ltd.

3701, 40, Simin-daero 365beon-gil,
Dongan-gu, Anyang-si, Gyeonggi-do, 14057, Korea
Tel: +82-31-425-6200 / Fax: +82-31-424-0450
www.kes.co.kr

Report No.:
KES-RF-18T0119
Page (47) of (107)

Mode: 802.11a

Test item	Low Frequency (5 500 MHz)	High Frequency (5 700 MHz)
99 % Bandwidth (MHz)	16.45	16.41

Mode: 802.11n(HT20)

Test item	Low Frequency (5 500 MHz)	High Frequency (5 700 MHz)
99 % Bandwidth (MHz)	17.64	17.62

Mode: 802.11ac(VHT20)

Test item	Low Frequency (5 500 MHz)	High Frequency (5 700 MHz)
99 % Bandwidth (MHz)	17.63	17.62

Mode: 802.11n(HT40)

Test item	Low Frequency (5 510 MHz)	High Frequency (5 670 MHz)
99 % Bandwidth (MHz)	36.22	36.22

Mode: 802.11ac(VHT40)

Test item	Low Frequency (5 510 MHz)	High Frequency (5 670 MHz)
99 % Bandwidth (MHz)	36.22	36.22

Mode: 802.11ac(VHT80)

Test item	Low Frequency (5 530 MHz)	High Frequency (5 610 MHz)
99 % Bandwidth (MHz)	75.05	75.02

This report shall not be reproduced except in full, without the written approval of KES Co., Ltd.
The results shown in this test report refer only to the sample(s) tested unless otherwise stated.
The authenticity of the test report, contact shchoi@kes.co.kr

Limit (Clause 4.2.2.2)

The Nominal Channel Bandwidth for a single Operating Channel shall be 20 MHz.

Alternatively, equipment may implement a lower *Nominal Channel Bandwidth* with a minimum of 5 MHz, providing they still comply with the *Nominal Centre Frequencies* defined in clause 4.2.1 (20 MHz raster).

The *Occupied Channel Bandwidth* shall be between 80 % and 100 % of the *Nominal Channel Bandwidth*. In case of smart antenna systems (devices with multiple transmit chains) each of the transmit chains shall meet this requirement.

The *Occupied Channel Bandwidth* might change with time/payload.

During a *Channel Occupancy Time (COT)*, equipment may operate temporarily with an *Occupied Channel Bandwidth* of less than 80 % of its *Nominal Channel Bandwidth* with a minimum of 2 MHz.

4.5. RF output power, Transmit Power Control (TPC) and power density

4.5.1 RF output power

Measurement Condition

Ambient temperature :	24.0 °C
Relative humidity :	40.2 % R.H.

Test procedure

EN 301 893 clause 5.4.4.2.1.1 – Option 1, 2 or 3
Used test method is option 2.

5.4.4.2.1.3

Option2: For equipment without continuous transmission capability and operating (or with the capability to operate) in only one sub-band

This option is for equipment that is either:

- equipment capable of operation in both sub-bands, but not simultaneously; or
- equipment capable of operation in both sub-bands simultaneously but which, for the purpose of the testing, can be configured to transmit only in one sub-band.

Equipment having simultaneous transmissions in both sub-bands and which cannot be configured to transmit only in one sub-band, shall be tested using option 3 given in clause 5.4.4.2.1.1.4.

- The test procedure shall be as follows:

Step 1:

- Sample the transmit signal from the device using a fast power sensor suitable for 6 GHz. Save the raw sample. The samples shall represent the RMS power of the signal.
- Settings:
 - Sample speed : $\geq 10^6$ Sample/s.
 - Measurement duration : Sufficient to capture a minimum of 10 transmitter bursts (see clause 5.3.1.1).

Step 2:

- For conducted measurements on devices with one transmit chain:
 - Connect the power sensor to the transmit port, sample the transmit signal and store the raw data. Use these stored samples in all following steps.
- For conducted measurements on devices with multiple transmit chains:
 - Connect a power sensor to each transmit port for a synchronous measurement on all transmit ports.
 - Trigger the power sensors so that they start sampling at the same time. Make sure the time difference between the samples of all sensors is less than 500 ns.
 - For each individual sampling point (time domain), sum the coincident power samples of all ports and store them. Use these summed samples in the following steps.

Step 3:

- Find the start and stop times of each burst in the stored measurement samples.
- The start and stop times are defined as the points where the power is at least 30 dB below the highest value of the stored samples in step 2.
- In case of insufficient dynamic range, the value of 30 dB may need to be reduced appropriately.

Step 4:

- Between the start and stop times of each individual burst, calculate the RMS (mean) power over the burst(P_{burst}) using the formula below:

$$P_{burst} = \frac{1}{k} \sum_{n=1}^k P_{sample}(n)$$

with 'k' being the total number of samples and 'n' the actual sample number

- The highest of all P_{burst} values is the value A in **dBm**.

Step 5:

- The RF output power (e.i.r.p) at the highest power level P_H shall be calculated from the above measured power output A (in **dBm**), the stated antenna assembly gain G in **dB** and if applicable the beamforming gain Y in **dB** according to the formula below. If more than one antenna assembly is intended for this power setting, the gain of the antenna assembly with the highest gain shall be used:

$$P_H = A + G + Y \text{ (dBm)}$$

- This value P_H shall be compared to the applicable limit contained in table 2 of clause 4.2.3.2.2 and shall be recorded in the report.

Test results

Mode: 802.11a

Test Temp.(°C)	Voltage(V)	E.I.R.P power (dBm)	
		Low Frequency (5 180 MHz)	High Frequency (5 320 MHz)
T min = -10	Min AC 207 V	10.64	10.70
	Max AC 240 V	10.65	10.71
T nom = 24	Nom AC 230 V	10.40	10.49
T max = 50	Min AC 207 V	10.14	10.19
	Max AC 240 V	10.18	10.22

Note:

1. E.I.R.P power (dBm) = Average Power(dBm) + Ant Gain(dBi) + Duty cycle
2. Antenna gain: 3.94 dBi
3. Duty cycle : $10\log(1/0.7729) = 1.12$

Mode: 802.11n(HT20)

Test Temp.(°C)	Voltage(V)	E.I.R.P power (dBm)	
		Low Frequency (5 180 MHz)	High Frequency (5 320 MHz)
T min = -10	Min AC 207 V	9.94	10.04
	Max AC 240 V	9.95	10.02
T nom = 24	Nom AC 230 V	9.53	9.65
T max = 50	Min AC 207 V	9.17	9.26
	Max AC 240 V	9.15	9.28

Note:

1. E.I.R.P power (dBm) = Average Power(dBm) + Ant Gain(dBi) + Duty cycle
2. Antenna gain: 3.94 dBi
3. Duty cycle : $10\log(1/0.8097) = 1.38$

Mode: 802.11ac(VHT20)

Test Temp.(°C)	Voltage(V)	E.I.R.P power (dBm)	
		Low Frequency (5 180 MHz)	High Frequency (5 320 MHz)
T min = -10	Min AC 207 V	10.73	10.79
	Max AC 240 V	10.72	10.79
T nom = 24	Nom AC 230 V	10.49	10.57
T max = 50	Min AC 207 V	10.17	10.24
	Max AC 240 V	10.20	10.26

Note:

1. E.I.R.P power (dBm) = Average Power(dBm) + Ant Gain(dBi) + Duty cycle
2. Antenna gain: 3.94 dBi
3. Duty cycle : $10\log(1/0.5834) = 2.34$

Mode: 802.11n(HT40)

Test Temp.(°C)	Voltage(V)	E.I.R.P power (dBm)	
		Low Frequency (5 190 MHz)	High Frequency (5 310 MHz)
T min = -10	Min AC 207 V	10.98	11.08
	Max AC 240 V	10.98	11.09
T nom = 24	Nom AC 230 V	10.73	10.91
T max = 50	Min AC 207 V	10.47	10.67
	Max AC 240 V	10.48	10.64

Note:

1. E.I.R.P power (dBm) = Average Power(dBm) + Ant Gain(dBi) + Duty cycle
2. Antenna gain: 3.94 dBi
3. Duty cycle : $10\log(1/0.5292) = 2.76$

Mode: 802.11ac(VHT40)

Test Temp.(°C)	Voltage(V)	E.I.R.P power (dBm)	
		Low Frequency (5 190 MHz)	High Frequency (5 310 MHz)
T min = -10	Min AC 207 V	11.72	11.96
	Max AC 240 V	11.70	11.94
T nom = 24	Nom AC 230 V	11.47	11.70
T max = 50	Min AC 207 V	11.18	11.52
	Max AC 240 V	11.20	11.51

Note:

1. E.I.R.P power (dBm) = Average Power(dBm) + Ant Gain(dBi) + Duty cycle
2. Antenna gain: 3.94 dBi
3. Duty cycle : $10\log(1/0.4442) = 3.52$

Mode: 802.11ac(VHT80)

Test Temp.(°C)	Voltage(V)	E.I.R.P power (dBm)	
		Low Frequency (5 210 MHz)	High Frequency (5 290 MHz)
T min = -10	Min AC 207 V	15.56	14.58
	Max AC 240 V	15.55	14.58
T nom = 24	Nom AC 230 V	15.32	14.26
T max = 50	Min AC 207 V	15.13	14.03
	Max AC 240 V	15.13	14.02

Note:

1. E.I.R.P power (dBm) = Average Power(dBm) + Ant Gain(dBi) + Duty cycle
2. Antenna gain: 3.94 dBi
3. Duty cycle : $10\log(1/0.1539) = 8.13$

Mode: 802.11a

Test Temp.(°C)	Voltage(V)	E.I.R.P power (dBm)	
		Low Frequency (5 500 MHz)	High Frequency (5 700 MHz)
T min = -10	Min AC 207 V	10.98	10.95
	Max AC 240 V	10.99	10.94
T nom = 24	Nom AC 230 V	10.77	10.72
T max = 50	Min AC 207 V	10.52	10.48
	Max AC 240 V	10.54	10.47

Note:

1. E.I.R.P power (dBm) = Average Power(dBm) + Ant Gain(dBi) + Duty cycle
2. Antenna gain: 3.94 dBi
3. Duty cycle : $10\log(1/0.8097) = 0.92$

Mode: 802.11n(HT20)

Test Temp.(°C)	Voltage(V)	E.I.R.P power (dBm)	
		Low Frequency (5 500 MHz)	High Frequency (5 700 MHz)
T min = -10	Min AC 207 V	9.82	9.78
	Max AC 240 V	9.80	9.80
T nom = 24	Nom AC 230 V	9.50	9.46
T max = 50	Min AC 207 V	9.24	9.22
	Max AC 240 V	9.26	9.21

Note:

1. E.I.R.P power (dBm) = Average Power(dBm) + Ant Gain(dBi) + Duty cycle
2. Antenna gain: 3.94 dBi
3. Duty cycle : $10\log(1/0.7999) = 0.97$

This report shall not be reproduced except in full, without the written approval of KES Co., Ltd.
 The results shown in this test report refer only to the sample(s) tested unless otherwise stated.
 The authenticity of the test report, contact shchoi@kes.co.kr

Mode: 802.11ac(VHT20)

Test Temp.(°C)	Voltage(V)	E.I.R.P power (dBm)	
		Low Frequency (5 500 MHz)	High Frequency (5 700 MHz)
T min = -10	Min AC 207 V	9.82	9.85
	Max AC 240 V	9.85	9.86
T nom = 24	Nom AC 230 V	9.55	9.57
T max = 50	Min AC 207 V	9.23	9.26
	Max AC 240 V	9.24	9.26

Note:

1. E.I.R.P power (dBm) = Average Power(dBm) + Ant Gain(dBi) + Duty cycle
2. Antenna gain: 3.94 dBi
3. Duty cycle : $10\log(1/0.7777) = 1.09$

Mode: 802.11n(HT40)

Test Temp.(°C)	Voltage(V)	E.I.R.P power (dBm)	
		Low Frequency (5 510 MHz)	High Frequency (5 670 MHz)
T min = -10	Min AC 207 V	9.16	8.82
	Max AC 240 V	9.19	8.86
T nom = 24	Nom AC 230 V	8.93	8.61
T max = 50	Min AC 207 V	8.72	8.38
	Max AC 240 V	8.77	8.41

Note:

1. E.I.R.P power (dBm) = Average Power(dBm) + Ant Gain(dBi) + Duty cycle
2. Antenna gain: 3.94 dBi
3. Duty cycle : $10\log(1/0.5998) = 2.22$

Mode: 802.11ac(VHT40)

Test Temp.(°C)	Voltage(V)	E.I.R.P power (dBm)	
		Low Frequency (5 510 MHz)	High Frequency (5 670 MHz)
T min = -10	Min AC 207 V	10.14	9.92
	Max AC 240 V	10.17	9.95
T nom = 24	Nom AC 230 V	9.91	9.70
T max = 50	Min AC 207 V	9.68	9.44
	Max AC 240 V	9.70	9.48

Note:

1. E.I.R.P power (dBm) = Average Power(dBm) + Ant Gain(dBi) + Duty cycle
2. Antenna gain: 3.94 dBi
3. Duty cycle : $10\log(1/0.4704) = 3.28$



KES Co., Ltd.

3701, 40, Simin-daero 365beon-gil,
Dongan-gu, Anyang-si, Gyeonggi-do, 14057, Korea
Tel: +82-31-425-6200 / Fax: +82-31-424-0450
www.kes.co.kr

Report No.:
KES-RF-18T0119
Page (55) of (107)

Mode: 802.11ac(VHT80)

Test Temp.(°C)	Voltage(V)	E.I.R.P power (dBm)	
		Low Frequency (5 530 MHz)	High Frequency (5 610 MHz)
T min = -10	Min AC 207 V	13.94	13.90
	Max AC 240 V	13.95	13.92
T nom = 24	Nom AC 230 V	13.70	13.66
T max = 50	Min AC 207 V	13.44	13.38
	Max AC 240 V	13.46	13.41

Note:

1. E.I.R.P power (dBm) = Average Power(dBm) + Ant Gain(dBi) + Duty cycle
2. Antenna gain: 3.94 dBi
3. Duty cycle : $10\log(1/0.1429) = 8.45$

This report shall not be reproduced except in full, without the written approval of KES Co., Ltd.
The results shown in this test report refer only to the sample(s) tested unless otherwise stated.
The authenticity of the test report, contact shchoi@kes.co.kr

4.5.2 Power spectral density

Measurement Condition

Ambient temperature : 24 °C
Relative humidity : 40.2 % R.H.

Test procedure

EN 301 893 clause 5.4.4.2.1.3 – Option 1 or 2
Used test method is option 1

5.4.4.2.1.3.2

Option 1: For equipment with continuous transmission capability or for equipment operating (or with the capability to operate) with a constant duty cycle (e.g. Frame Based equipment)

This option is for equipment that can be configured to operate in a continuous transmit mode or with a constant duty cycle (x).

Step 1:

Connect the UUT to the spectrum analyser and use the following settings:

1. Centre frequency : The centre frequency of the channel under test
2. RBW : 1 MHz
3. VBW : 3 MHz
4. Frequency span : $2 \times$ Nominal Bandwidth (e.g. 40 MHz for a 20 MHz channel)
5. Detector mode : Peak
6. Trace mode : Max hold

Step 2:

When the trace is complete, find the peak value of the power envelope and record the frequency.

1. Centre frequency : Equal to the frequency recorded in step 2
2. Frequency span : 3 MHz
3. RBW : 1 MHz
4. VBW : 3 MHz
5. Sweep time : 1 minute
6. Detector mode : RMS
7. Trace mode : Max hold

Step 4:

- When the trace is complete, the trace shall be captured using the "Hold" or "View" option on the spectrum analyser.
- Find the peak value of the trace and place the analyser marker on this peak. This level is recorded as the highest Mean power (Power Density) D in a 1 MHz band.
- Alternatively, where a spectrum analyser is equipped with a function to measure spectral Power Density, this function may be used to display the Power Density D in dBm/MHz.
- In case of conducted measurements on smart antenna systems operating in a mode with multiple transmit chains active simultaneously, the Power Density of each transmit chain shall be measured separately to calculate the total Power Density (value D in dBm/MHz) for the UUT.

Step 5:

- The maximum spectral Power Density e.i.r.p. is calculated from the above measured Power Density D, the observed duty cycle x (see clause 5.4.4.2.1.1.2, step 1), the applicable antenna assembly gain G in dBi and if applicable the beamforming gain Y in dB, according to the formula below. This value shall be recorded in the test report. If more than one antenna assembly is intended for this power setting, the gain of the antenna assembly with the highest gain shall be used:

$$PD = D + G + Y + 10 \times \log(1/x) \text{ (dBm/MHz)}$$

5.4.4.2.1.3.3

Option 2 : For equipment without continuous transmission capability and without the capability to transmit with a constant duty cycle

The test procedure shall be as follows:

Step1 :

Connect the UUT to the spectrum analyser and use the following settings:

1. Start frequency : lower band edge of applicable sub-band (e.g. 5 150 MHz or 5 470 MHz)
2. Stop frequency : upper band edge of applicable sub-band (e.g. 5 350 MHz or 5 725 MHz)
3. RBW : 10 kHz
4. VBW : 30 kHz
5. Sweep points : >20 000 (for 5 150 MHz or 5 350 MHz)
 >25 500 (for 5 470 MHz or 5 725 MHz)
 For spectrum analysers not supporting this number of sweep points, the frequency band may be segmented.
6. Detector : RMS
7. Trace mode : Max hold
8. Sweep time : 30 s

For non-continuous signals, wait for the trace to be stabilized. Save the (trace) data set to a file.

Step 2:

- For conducted measurements on smart antenna systems using either operating mode 2 or operating mode 3 (see clause 5.3.3.2), repeat the measurement for each of the transmit ports. For each sampling point (frequency domain), add up the coincident power values (in mW) for the different transmit chains and use this as the new data set.

Step 3:

- Add up the values of power for all the samples in the file using the formula below:

$$P_{\text{Sum}} = \sum_{n=1}^k P_{\text{sample}}(n)$$

With 'k' being the total number of sample and 'n' the actual sample number

Step 4:

- Normalize the individual values for power (in dBm) so that the sum is equal to the RF Output Power (e.i.r.p.) (P_H) measured in clause 5.4.4.2.1.1 for this sub-band. The following formulas can be used:

$$C_{\text{Corr}} = P_{\text{Sum}} - P_{H \text{ e.i.r.p}}$$

$$P_{\text{Samplecorr}}(n) = P_{\text{Sample}}(n) - C_{\text{Corr}}$$

With 'n' being the actual sample number

Step 5:

- Starting from the first sample $P_{\text{Samplecorr}}(n)$ in the file (lowest frequency), add up the power (in mW) of the following samples representing a 1 MHz segment and record the results for power and position (i.e. sample #1 to sample #100). This is the Power Density (e.i.r.p.) for the first 1 MHz segment which shall be saved.

Step 6:

- Shift the start point of the samples added up in step 5 by one sample and repeat the procedure in step 5 (i.e. sample #2 to sample #101).

Step 7:

- Repeat step 6 until the end of the data set and save the radiated Power Density values for each of the 1MHz segments.
- From all the saved results, the highest value is the maximum Power Density (e.i.r.p.) for the UUT. This value, which shall comply with the limit contained in table 2 of clause 4.2.3.2.2, shall be recorded in the test report.

Test results

Mode: 802.11a

Temperature(°C)	Voltage(V)	Power spectral density (dBm/MHz)	
		Low Frequency (5 180 MHz)	High Frequency (5 320 MHz)
Nom. 24	Nom. AC 230 V	-2.54	-3.57

Note:

1. E.I.R.P. Power spectral density (dBm/MHz) = Power spectral density (dBm/MHz) + Ant Gain(dBi) + Duty cycle
2. Antenna gain: 3.94 dBi
3. Duty cycle : $10\log(1/0.7729) = 1.12$

Mode: 802.11n(HT20)

Temperature(°C)	Voltage(V)	Power spectral density (dBm/MHz)	
		Low Frequency (5 180 MHz)	High Frequency (5 320 MHz)
Nom. 24	Nom. AC 230 V	-5.30	-5.60

Note:

1. E.I.R.P. Power spectral density (dBm/MHz) = Power spectral density (dBm/MHz) + Ant Gain(dBi) + Duty cycle
2. Antenna gain: 3.94 dBi
3. Duty cycle : $10\log(1/0.8097) = 1.38$

Mode: 802.11ac(VHT20)

Temperature(°C)	Voltage(V)	Power spectral density (dBm/MHz)	
		Low Frequency (5 180 MHz)	High Frequency (5 320 MHz)
Nom. 24	Nom. AC 230 V	-5.01	-5.45

Note:

1. E.I.R.P. Power spectral density (dBm/MHz) = Power spectral density (dBm/MHz) + Ant Gain(dBi) + Duty cycle
2. Antenna gain: 3.94 dBi
3. Duty cycle : $10\log(1/0.5834) = 2.34$

Mode: 802.11n(HT40)

Temperature(°C)	Voltage(V)	Power spectral density (dBm/MHz)	
		Low Frequency (5 190 MHz)	High Frequency (5 310 MHz)
Nom. 24	Nom. AC 230 V	-7.52	-8.86

Note:

1. E.I.R.P. Power spectral density (dBm/MHz) = Power spectral density (dBm/MHz) + Ant Gain(dBi) + Duty cycle
2. Antenna gain: 3.94 dBi
3. Duty cycle : $10\log(1/0.529\ 2) = 2.76$

Mode: 802.11ac(VHT40)

Temperature(°C)	Voltage(V)	Power spectral density (dBm/MHz)	
		Low Frequency (5 190 MHz)	High Frequency (5 310 MHz)
Nom. 24	Nom. AC 230 V	-7.35	-8.09

Note:

1. E.I.R.P. Power spectral density (dBm/MHz) = Power spectral density (dBm/MHz) + Ant Gain(dBi) + Duty cycle
2. Antenna gain: 3.94 dBi
3. Duty cycle : $10\log(1/0.444\ 2) = 3.52$

Mode: 802.11ac(VHT80)

Temperature(°C)	Voltage(V)	Power spectral density (dBm/MHz)	
		Low Frequency (5 210 MHz)	High Frequency (5 290 MHz)
Nom. 24	Nom. AC 230 V	-4.53	-5.08

Note:

1. E.I.R.P. Power spectral density (dBm/MHz) = Power spectral density (dBm/MHz) + Ant Gain(dBi) + Duty cycle
2. Antenna gain: 3.94 dBi
3. Duty cycle : $10\log(1/0.153\ 9) = 8.13$

Mode: 802.11a

Temperature(°C)	Voltage(V)	Power spectral density (dBm/MHz)	
		Low Frequency (5 500 MHz)	High Frequency (5 700 MHz)
Nom. 24	Nom. AC 230 V	-4.44	-4.02

Note:

1. E.I.R.P. Power spectral density (dBm/MHz) = Power spectral density (dBm/MHz) + Ant Gain(dBi) + Duty cycle
2. Antenna gain: 3.94 dBi
3. Duty cycle : $10\log(1/0.8097) = 0.92$

Mode: 802.11n(HT20)

Temperature(°C)	Voltage(V)	Power spectral density (dBm/MHz)	
		Low Frequency (5 500 MHz)	High Frequency (5 700 MHz)
Nom. 24	Nom. AC 230 V	-5.70	-6.17

Note:

1. E.I.R.P. Power spectral density (dBm/MHz) = Power spectral density (dBm/MHz) + Ant Gain(dBi) + Duty cycle
2. Antenna gain: 3.94 dBi
3. Duty cycle : $10\log(1/0.7999) = 0.97$

Mode: 802.11ac(VHT20)

Temperature(°C)	Voltage(V)	Power spectral density (dBm/MHz)	
		Low Frequency (5 500 MHz)	High Frequency (5 700 MHz)
Nom. 24	Nom. AC 230 V	-6.16	-6.65

Note:

1. E.I.R.P. Power spectral density (dBm/MHz) = Power spectral density (dBm/MHz) + Ant Gain(dBi) + Duty cycle
2. Antenna gain: 3.94 dBi
3. Duty cycle : $10\log(1/0.7777) = 1.09$

Mode: 802.11n(HT40)

Temperature(°C)	Voltage(V)	Power spectral density (dBm/MHz)	
		Low Frequency (5 510 MHz)	High Frequency (5 670 MHz)
Nom. 24	Nom. AC 230 V	-6.90	-6.94

Note:

1. E.I.R.P. Power spectral density (dBm/MHz) = Power spectral density (dBm/MHz) + Ant Gain(dBi) + Duty cycle
2. Antenna gain: 3.94 dBi
3. Duty cycle : $10\log(1/0.599\ 8) = 2.22$

Mode: 802.11ac(VHT40)

Temperature(°C)	Voltage(V)	Power spectral density (dBm/MHz)	
		Low Frequency (5 510 MHz)	High Frequency (5 670 MHz)
Nom. 24	Nom. AC 230 V	-7.00	-7.49

Note:

1. E.I.R.P. Power spectral density (dBm/MHz) = Power spectral density (dBm/MHz) + Ant Gain(dBi) + Duty cycle
2. Antenna gain: 3.94 dBi
3. Duty cycle : $10\log(1/0.470\ 4) = 3.28$

Mode: 802.11ac(VHT80)

Temperature(°C)	Voltage(V)	Power spectral density (dBm/MHz)	
		Low Frequency (5 530 MHz)	High Frequency (5 610 MHz)
Nom. 24	Nom. AC 230 V	-5.15	-5.52

Note:

1. E.I.R.P. Power spectral density (dBm/MHz) = Power spectral density (dBm/MHz) + Ant Gain(dBi) + Duty cycle
2. Antenna gain: 3.94 dBi
3. Duty cycle : $10\log(1/0.142\ 9) = 8.45$

Limit (Clause 4.2.3.2.2)

TPC is not required for channels whose nominal bandwidth falls completely within the band 5 150 MHz to 5 250 MHz.

For devices with TPC, the RF output power and the power density when configured to operate at the highest stated power level (P_H) of the TPC range shall not exceed the levels given in table 2.

Devices are allowed to operate without TPC. See table 2 for the applicable limits in this case.

Table 2: Mean e.i.r.p. limits for RF output power and power density at the highest power level (P_H)

Frequency range [MHz]	Mean EIRP limit [dBm]		Mean EIRP density limit [dBm/MHz]	
	with TPC	Without TPC	with TPC	Without TPC
5 150 to 5 350	23	<u>20 / 23 (see note 1)</u>	10	<u>7 / 10 (see note 2)</u>
5 470 to 5 725	30 (see note 3)	<u>27 (see note 3)</u>	17 (see note 3)	<u>14 (see note 3)</u>

NOTE 1: The applicable limit is 20 dBm, except for transmissions whose nominal bandwidth falls completely within the band 5 150 MHz to 5 250 MHz, in which case the applicable limit is 23 dBm.
 NOTE 2: The applicable limit is 7 dBm/MHz, except for transmissions whose nominal bandwidth falls completely within the band 5 150 MHz to 5 250 MHz, in which case the applicable limit is 10 dBm/MHz.
 NOTE 3: Slave devices without a Radar Interference Detection function shall comply with the limits for the band 5 250 MHz to 5 350 MHz.

4.6. Transmitter unwanted emissions within the 5 GHz RLAN bands

Measurement Condition

Ambient temperature : 26 °C
Relative humidity : 24 % R.H.

Test procedure

EN 301 893 clause 5.4.6.2 – Option 1 or 2
Used test method is option 2

5.4.6.2.1

Option 1 : For equipment with continuous transmission capability

The UUT shall be configured for continuous transmit mode (duty cycle equal to 100 %). If this is not possible, then option 2 shall be used.

Step 1: Determination of the reference average power level.

- Spectrum analyser settings:
 1. RBW : 1 MHz
 2. VBW : 30 kHz
 3. Detector mode : Peak
 4. Trace mode : Video average
 5. Sweep time : Coupled
 6. Centre frequency : Centre frequency of the channel being tested
 7. Span : 2 × Nominal channel bandwidth
- Use the marker to find the highest average power level of the power envelope of the UUT. This level shall be used as the reference level for the relative measurements.

Step2 : Determination of the relative average power levels.

- Adjust the frequency range of the spectrum analyser to allow the measurement to be performed within the sub-bands 5 150 MHz to 5 350 MHz and 5 470 MHz to 5 725 MHz. No other parameter of the spectrum analyser should be changed.
- Compare the relative power envelope of the UUT with the limits defined in clause 4.2.4.2.2.

5.4.6.2.1.2

Option 2: For equipment without continuous transmission capability

This method shall be used if the UUT is not capable of operating in a continuous transmit mode (duty cycle less than 100 %). In addition, this option can also be used as an alternative to option 1 for systems operating in a continuous transmit mode.

Step 1: Determination of the reference average power level.

Spectrum analyser settings:

1. RBW : 1 MHz
2. VBW : 30 kHz
3. Detector mode : RMS
4. Trace mode : Max hold
5. Sweep time : 1 min
6. Centre frequency : Centre frequency of the channel being tested
7. Span : $2 \times$ Nominal channel bandwidth

Use the marker to find the highest average power level of the power envelope of the UUT. This level shall be used as the reference level for the relative measurements.

Step 2: Determination of the relative average power levels

Adjust the frequency range of the spectrum analyser to allow the measurement to be performed within the sub-bands 5 150 MHz to 5 350 MHz and 5 470 MHz to 5 725 MHz. No other parameter of the spectrum analyser should be changed.

Compare the relative power envelope of the UUT with the limits defined in clause 4.2.4.2.2.

Test results

5 180 MHz 11a

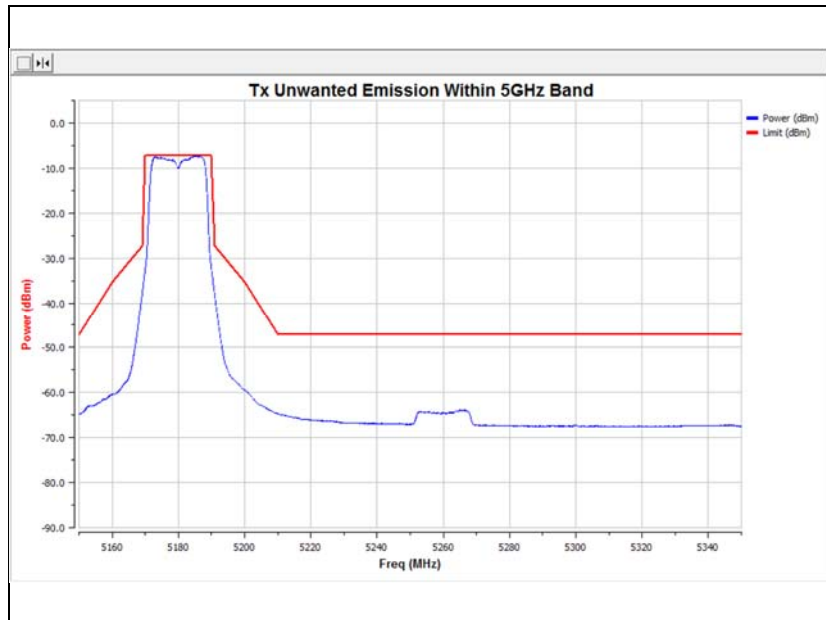

5 320 MHz 11a

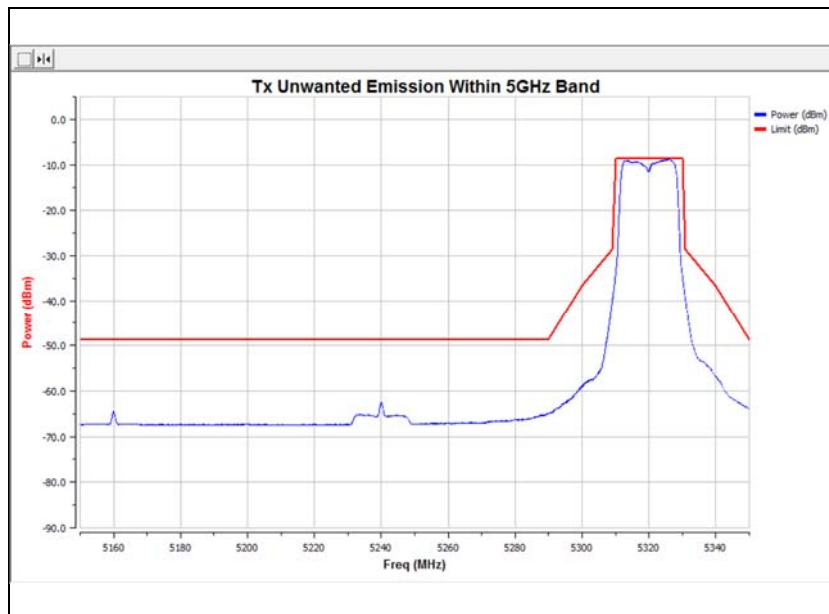

This report shall not be reproduced except in full, without the written approval of KES Co., Ltd.
 The results shown in this test report refer only to the sample(s) tested unless otherwise stated.
 The authenticity of the test report, contact shchoi@kes.co.kr

5 500 MHz 11a

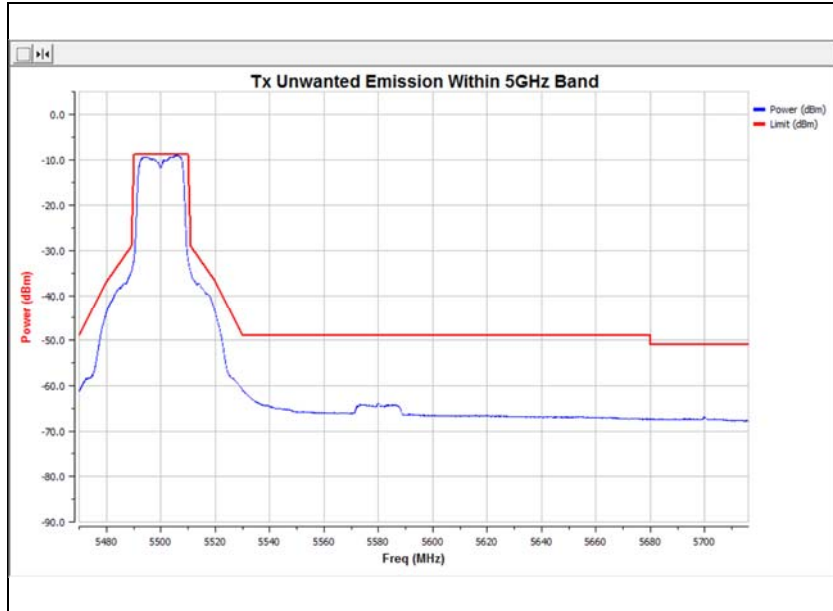

5 700 MHz 11a

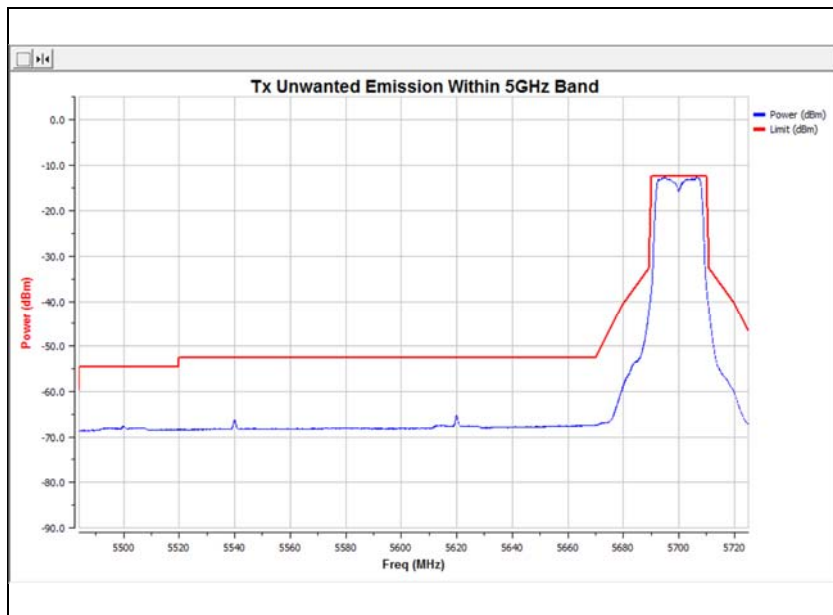

This report shall not be reproduced except in full, without the written approval of KES Co., Ltd.
 The results shown in this test report refer only to the sample(s) tested unless otherwise stated.
 The authenticity of the test report, contact shchoi@kes.co.kr

5 180 MHz 11n_HT20

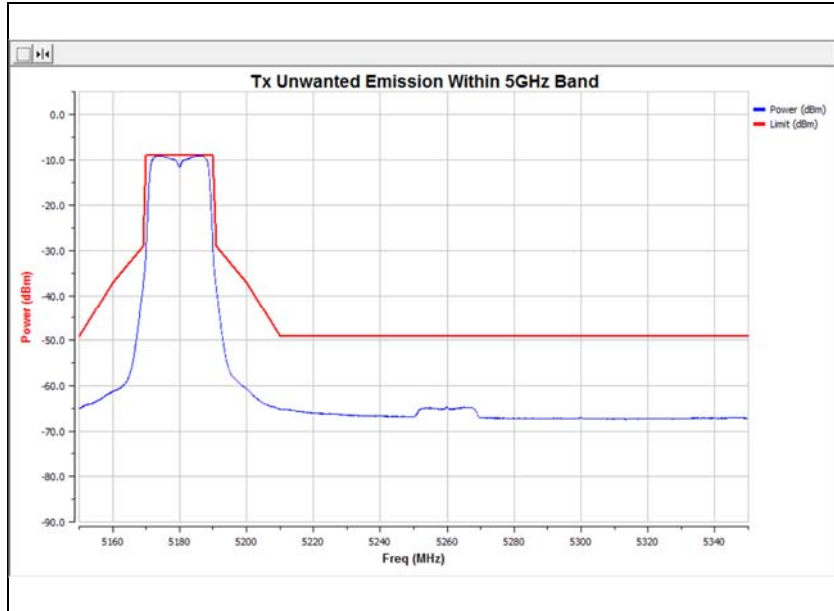

5 320 MHz 11n_HT20

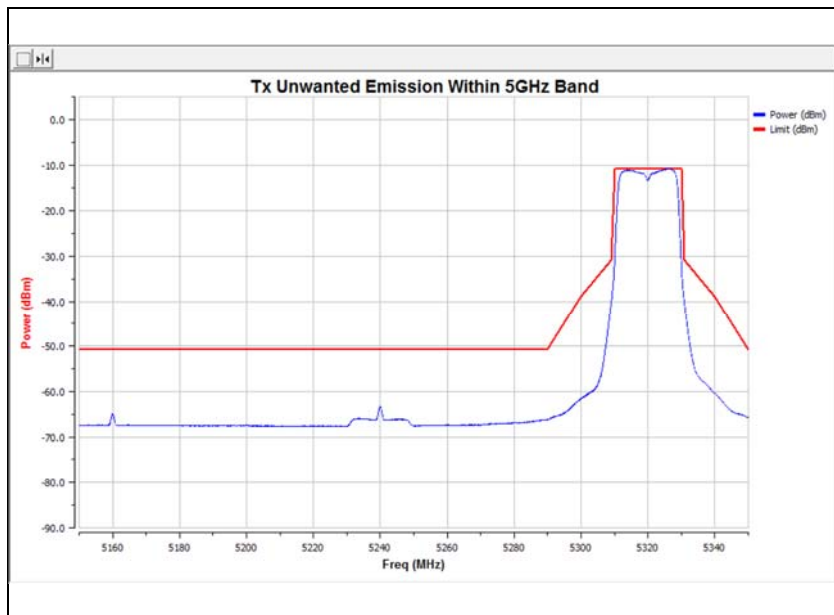

This report shall not be reproduced except in full, without the written approval of KES Co., Ltd.
 The results shown in this test report refer only to the sample(s) tested unless otherwise stated.
 The authenticity of the test report, contact shchoi@kes.co.kr

5 500 MHz 11n_HT20

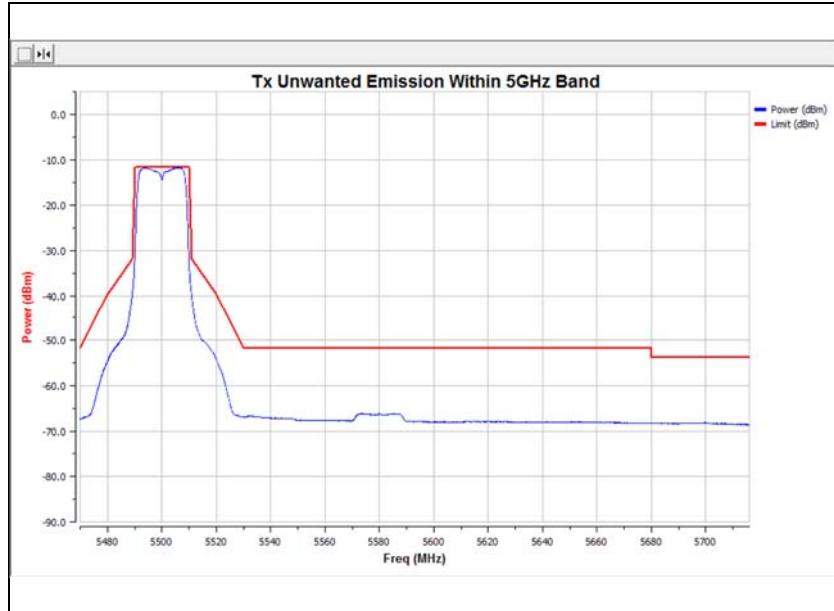

5 700 MHz 11n_HT20

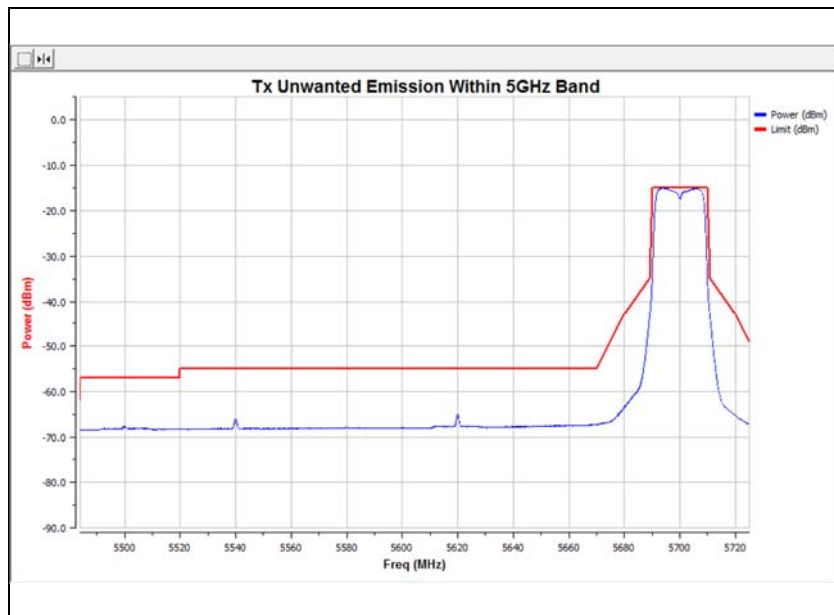

This report shall not be reproduced except in full, without the written approval of KES Co., Ltd.
 The results shown in this test report refer only to the sample(s) tested unless otherwise stated.
 The authenticity of the test report, contact shchoi@kes.co.kr

5 180 MHz 11ac_VHT20

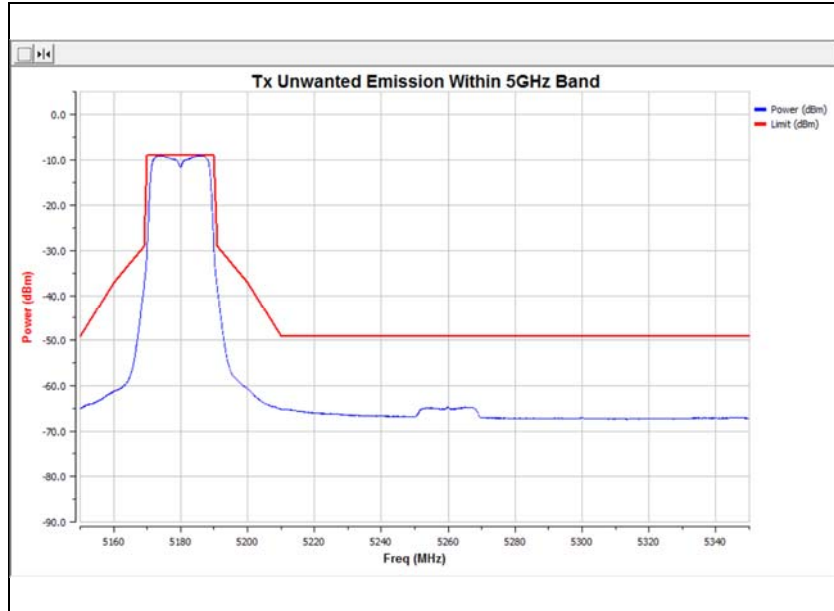

5 320 MHz 11ac_VHT20

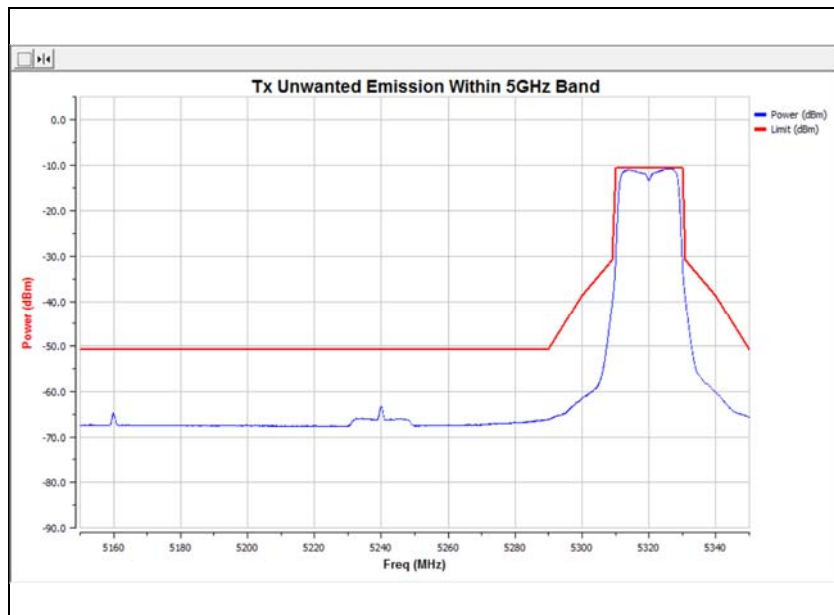

This report shall not be reproduced except in full, without the written approval of KES Co., Ltd.
 The results shown in this test report refer only to the sample(s) tested unless otherwise stated.
 The authenticity of the test report, contact shchoi@kes.co.kr

5 500 MHz 11ac_VHT20

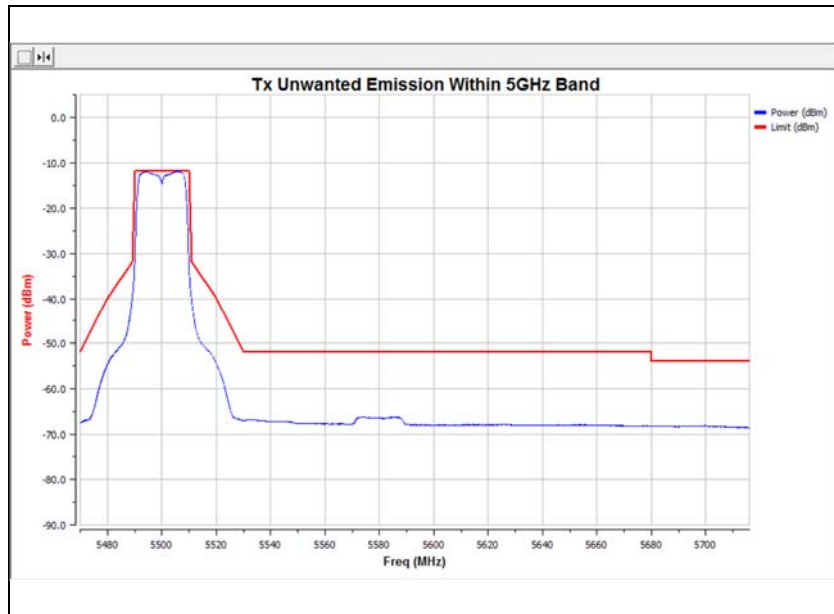

5 700 MHz 11ac_VHT20

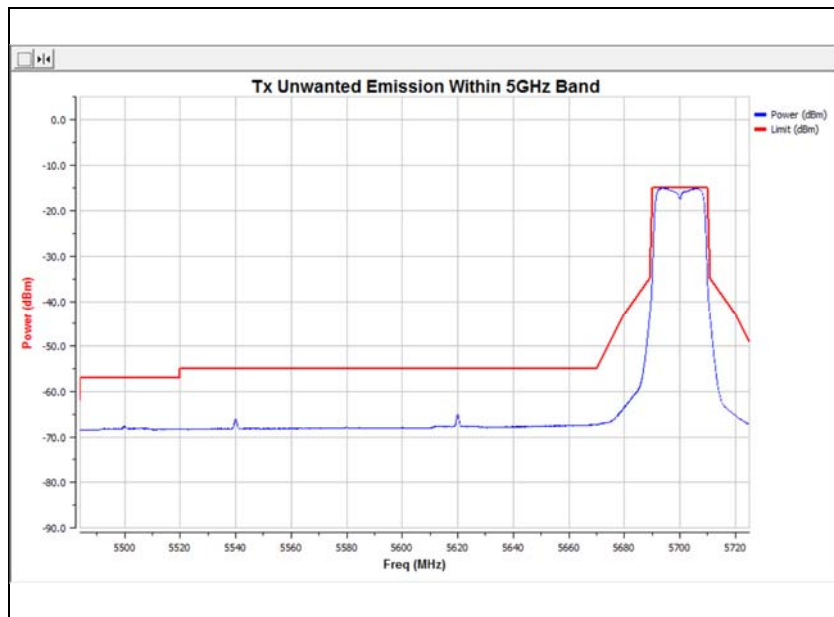

This report shall not be reproduced except in full, without the written approval of KES Co., Ltd.
 The results shown in this test report refer only to the sample(s) tested unless otherwise stated.
 The authenticity of the test report, contact shchoi@kes.co.kr

5 190 MHz 11n_HT40

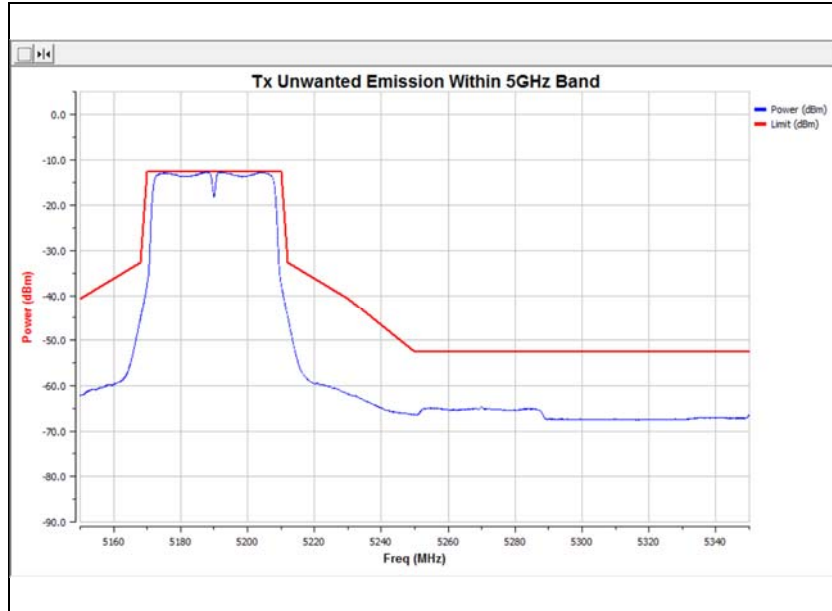

5 310 MHz 11n_HT40

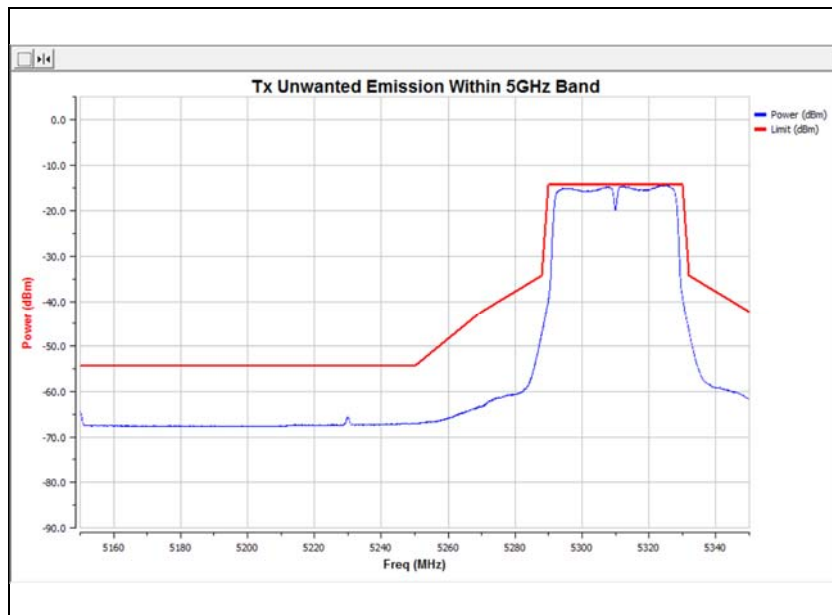

This report shall not be reproduced except in full, without the written approval of KES Co., Ltd.
 The results shown in this test report refer only to the sample(s) tested unless otherwise stated.
 The authenticity of the test report, contact shchoi@kes.co.kr

5 510 MHz 11n_HT40

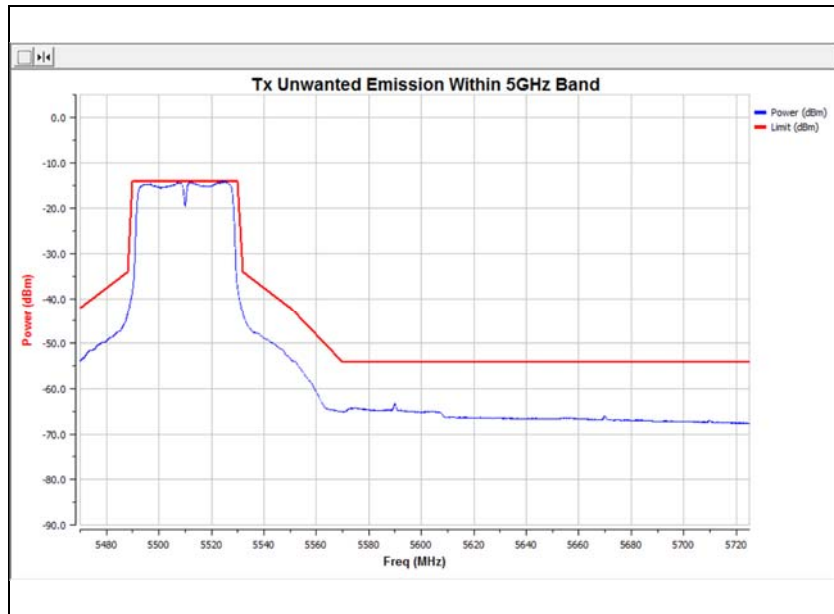

5 670 MHz 11n_HT40

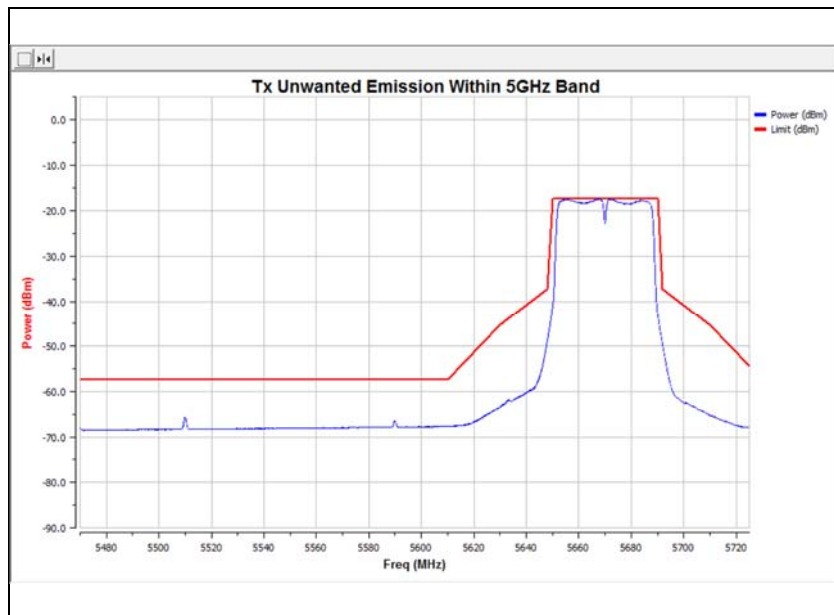

This report shall not be reproduced except in full, without the written approval of KES Co., Ltd.
 The results shown in this test report refer only to the sample(s) tested unless otherwise stated.
 The authenticity of the test report, contact shchoi@kes.co.kr

5 190 MHz 11ac_VHT40

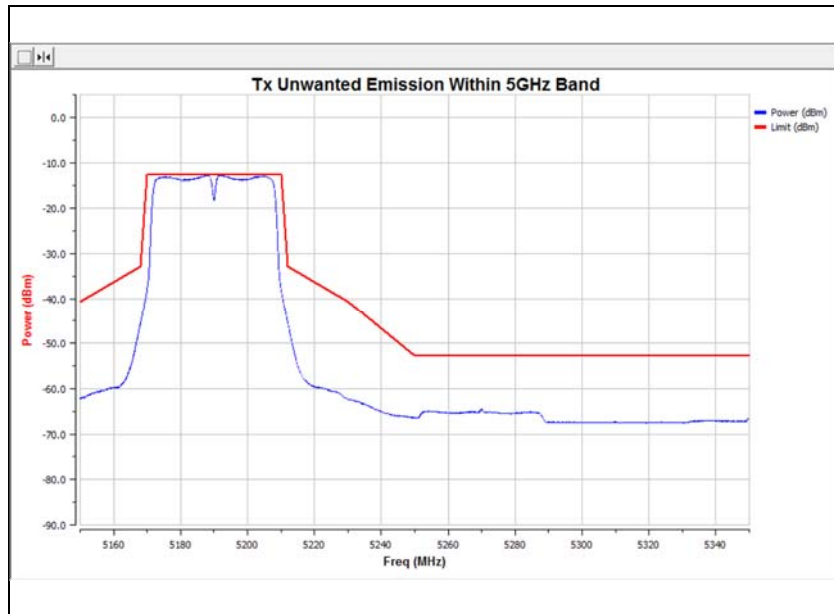

5 310 MHz 11ac_VHT40

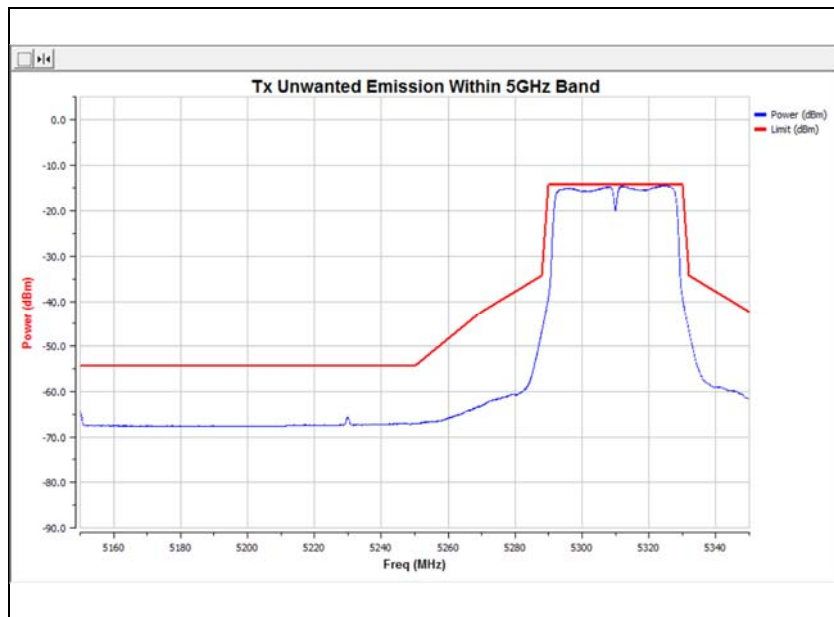

This report shall not be reproduced except in full, without the written approval of KES Co., Ltd.
 The results shown in this test report refer only to the sample(s) tested unless otherwise stated.
 The authenticity of the test report, contact shchoi@kes.co.kr

5 510 MHz 11ac_VHT40

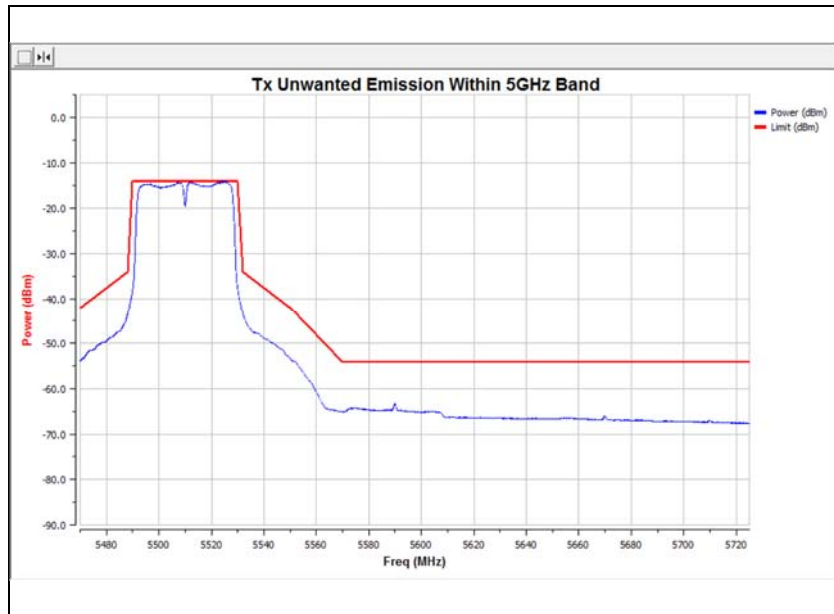

5 670 MHz 11ac_VHT40

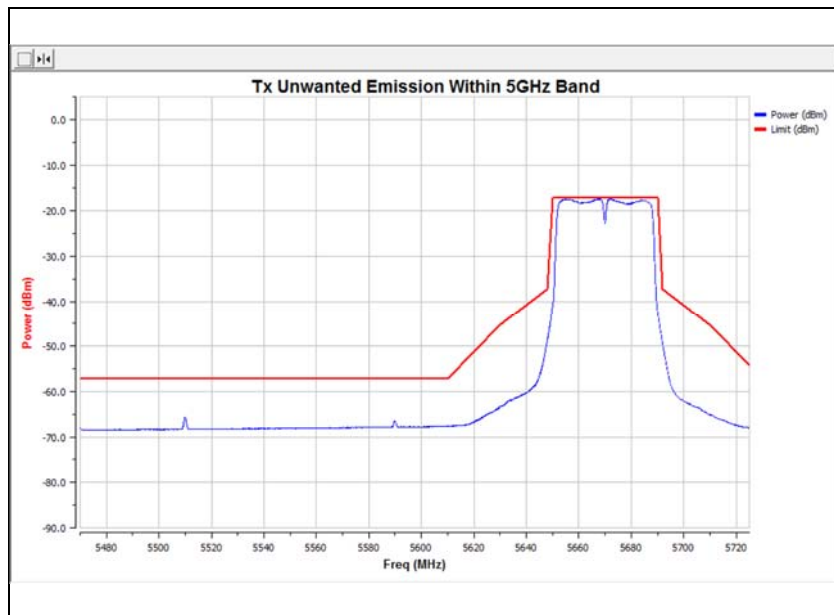

This report shall not be reproduced except in full, without the written approval of KES Co., Ltd.
 The results shown in this test report refer only to the sample(s) tested unless otherwise stated.
 The authenticity of the test report, contact shchoi@kes.co.kr

Limit (Clause 4.2.4.2.2)

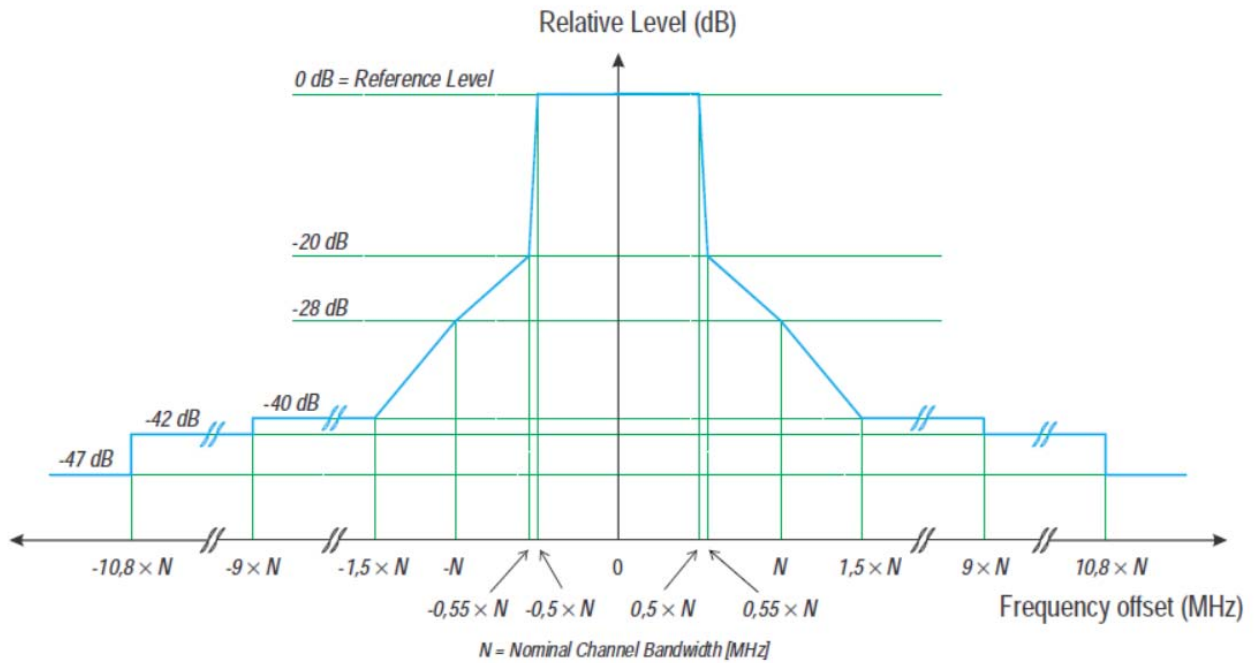

This report shall not be reproduced except in full, without the written approval of KES Co., Ltd.
 The results shown in this test report refer only to the sample(s) tested unless otherwise stated.
 The authenticity of the test report, contact shchoi@kes.co.kr

4.7. DFS (Dynamic Frequency Selection)

Measurement Condition

Ambient temperature : 24.0 °C
 Relative humidity : 40.2 % R.H.

4.7.1 Carrier frequencies table

Channel bandwidth 20 MHz

Frequency Band	Channel No.	Frequency(MHz)
5 250 ~ 5 350 MHz Band 2	52	5 260
	60	5 300
	64	5 320
5 470 ~ 5 725 MHz Band 3	100	5 500
	116	5 580
	140	5 700

Channel bandwidth 40 MHz

Frequency Band	Channel No.	Frequency(MHz)
5 250 ~ 5 350 MHz Band 2	54	5 270
	62	5 310
5 470 ~ 5 725 MHz Band 3	102	5 510
	118	5 590
	134	5 670

Channel bandwidth 80 MHz

Frequency Band	Channel No.	Frequency(MHz)
5 250 ~ 5 350 MHz Band 2	58	5 290
5 470 ~ 5 725 MHz Band 3	106	5 530
	122	5 610

4.7.2 Test setup

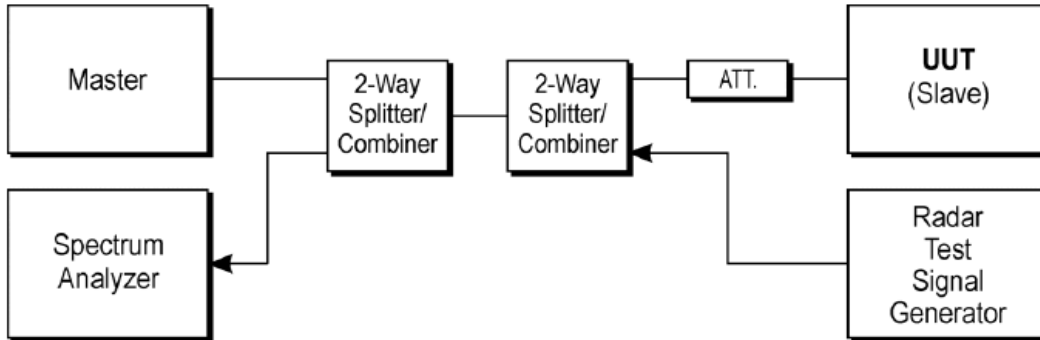

Figure 5: Set-up B

Set-up B is set-up whereby the UUT is an RLAN device operating in slave mode, with or without Radar Interference Detection function. This set-up also contains an RLAN device operating in master mode. The radar test signals are injected into the master device. The UUT (slave device) is associated with the master device.

Figure 5 shows an example for Set-up B. The set-up used shall be documented in the test report.

4.7.3 Applicability

Table 6 lists the DFS related technical requirements and their applicability for every operational mode. If the RLAN device is capable of operating in more than one operational mode then every operating mode shall be assessed separately.

Table 6 : Applicability of DFS requirements

Requirement	DFS Operational mode		
	Master	Slave without radar detection (see table D.2, note 2)	Slave with radar detection (see table D.2, note 2)
Channel Availability Check	Required	Not required	Required (see note 2)
Off-Channel CAC (see note 1)	Required	Not required	Required (see note 2)
In-Service Monitoring	Required	Not required	Required
Channel Shutdown	Required	Required	Required
Non-Occupancy Period	Required	Not required	Required
Uniform Spreading	Required	Not required	Not required

NOTE 1: Where implemented by the manufacturer.
 NOTE 2: A slave with radar detection is not required to perform a CAC or Off-Channel CAC at initial use of the channel but only after the slave has detected a radar signal on the *Operating Channel* by *In-Service Monitoring* and the *Non-Occupancy Period* resulting from this detection has elapsed.

The radar detection requirements specified in clauses 4.2.6.2.2 to 4.2.6.2.4 assume that the centre frequencies of the radar signals fall within the central 80% of the Occupied Channel Bandwidth of the RLAN channel (see clause 4.2.2)

4.7.4. Test result

4.7.4.1 Traffic load

Mode: 802.11ac_VHT80
 Operating frequency: 5 290 MHz

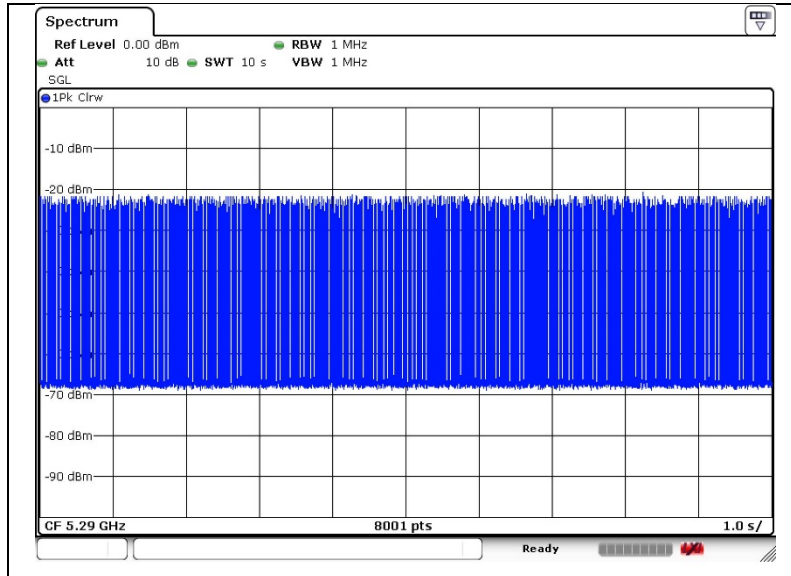

Mode: 802.11ac(VHT80)
 Channel: 5 530 MHz

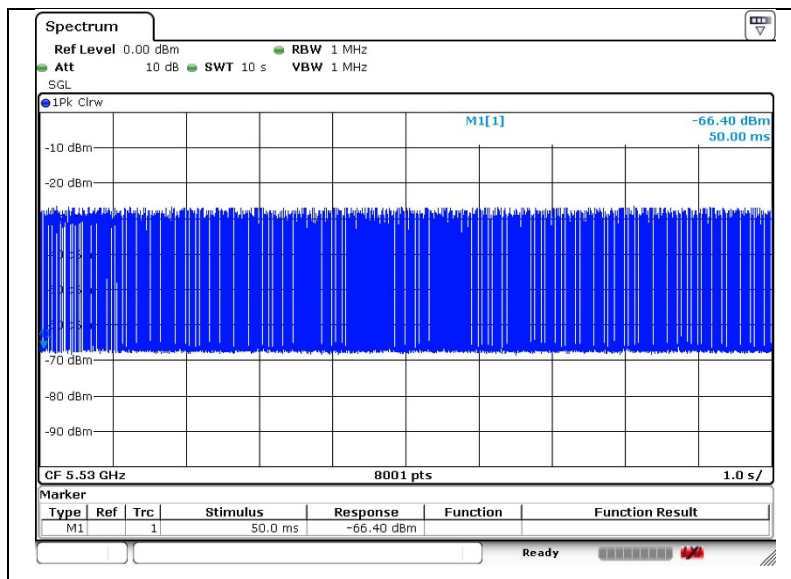

This report shall not be reproduced except in full, without the written approval of KES Co., Ltd.
 The results shown in this test report refer only to the sample(s) tested unless otherwise stated.
 The authenticity of the test report, contact shchoi@kes.co.kr

4.7.4.2 Channel move time & channel closing transmission time

Mode: 802.11ac_VHT80
 Operating frequency: 5 290 MHz

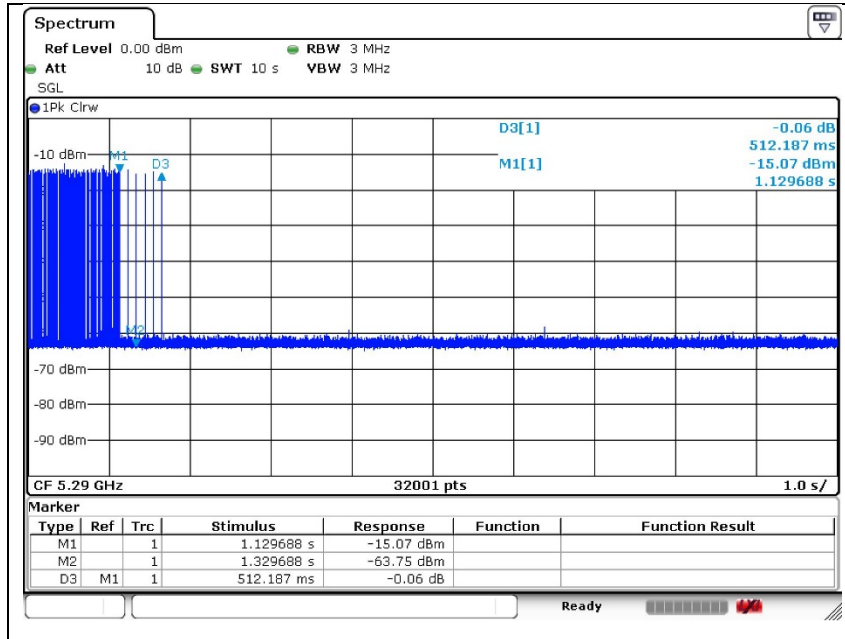

Channel closing transmission time calculated	Test results
Sweep time[S] sec	10
Sampling bins[B]	32 001
Number of sampling bins in 10 sec[N]	1
Closing transmission time [C] ms	0.312

Channel move time (s)	Limit
0.512	≤ 10 s

Note:

Dwell = S/B;

Where **dw**ell is the dwell time per spectrum analyzer sampling bin, **S** is the sweep time and **B** is the number of spectrum analyzer sampling bins.

An upper bound of the aggregate duration of the channel closing transmission time is calculated by:

C = N × Dwell;

Where **C** is the closing time, **N** is the number of spectrum analyzer sampling bins showing a U-NII transmission and **dw**ell is the dwell time per bin.

Dwell = [S] / [B] = 10 / 32001 = 0.000312

Closing Transmission Time[C] = [N] × [Dwell] = 1 × 0.000312 = 0.000312 s = 0.312 ms

Mode: 802.11ac_VHT80
 Operating frequency: 5 530 MHz

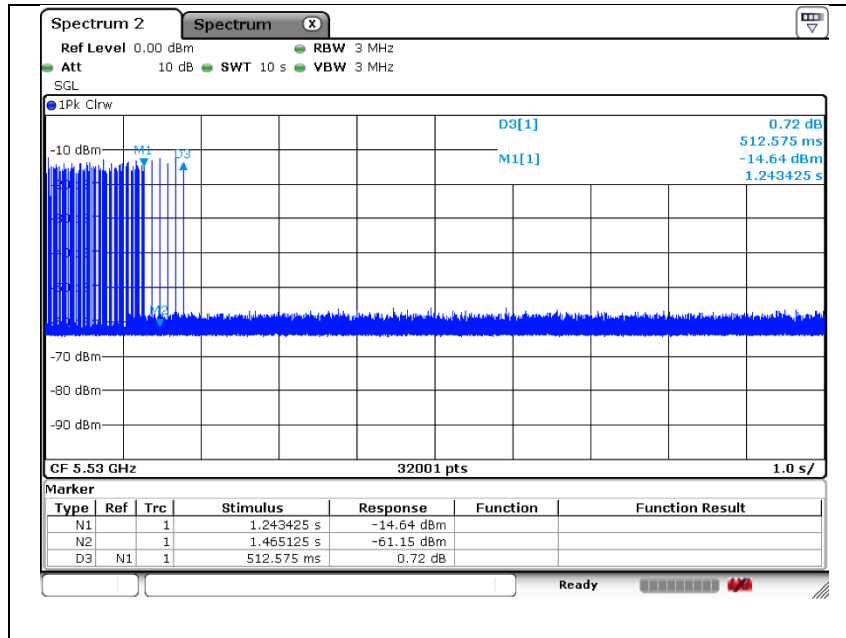

Channel closing transmission time calculated	Test results
Sweep time[S] sec	10
Sampling bins[B]	32 001
Number of sampling bins in 10 sec[N]	1
Closing transmission time [C] ms	0.312

Channel move time (s)	Limit
0.513	≤ 10 s

Note:

Dwell = S/B;

Where **dwell** is the dwell time per spectrum analyzer sampling bin, **S** is the sweep time and **B** is the number of spectrum analyzer sampling bins.

An upper bound of the aggregate duration of the channel closing transmission time is calculated by:

C = N × Dwell;

Where **C** is the closing time, **N** is the number of spectrum analyzer sampling bins showing a U-NII transmission and **dwell** is the dwell time per bin.

Dwell = [S] / [B] = 10 / 32001 = 0.000312

Closing Transmission Time[C] = [N] × [Dwell] = 1 × 0.000312 = 0.000312 s = 0.312 ms

4.7.4.3 Non-Occupancy Period

Mode: 802.11ac_VHT80
 Operating frequency: 5 290 MHz

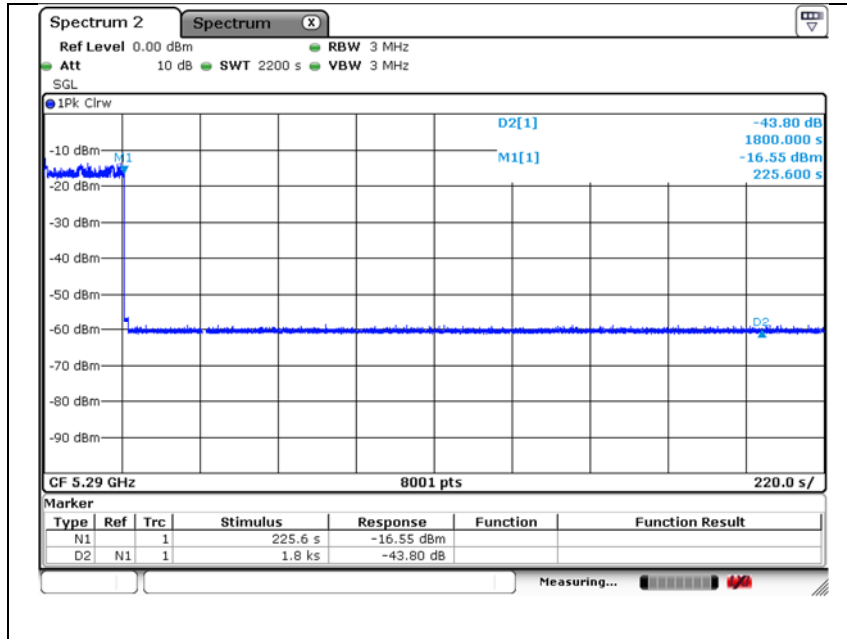

Mode: 802.11ac_VHT80
 Operating frequency: 5 530 MHz

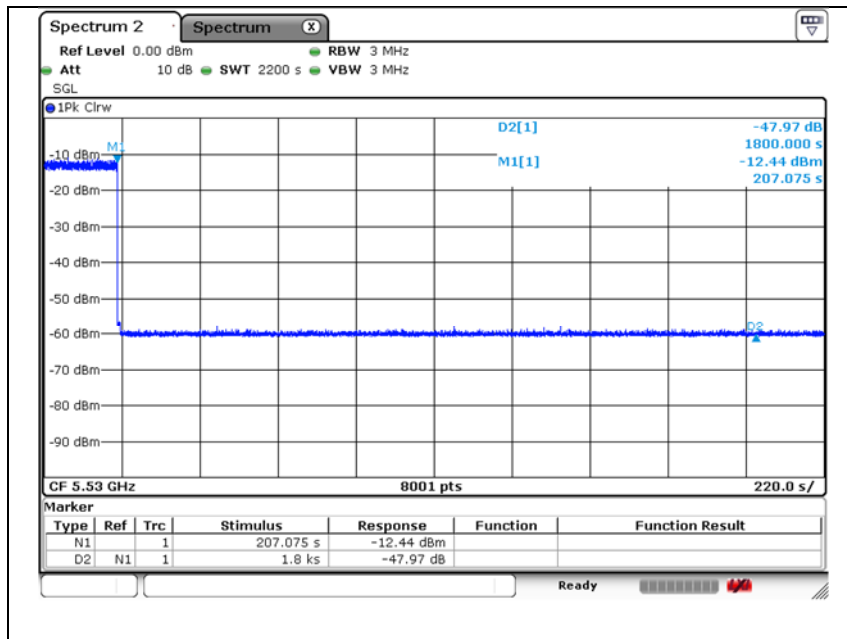

This report shall not be reproduced except in full, without the written approval of KES Co., Ltd.
 The results shown in this test report refer only to the sample(s) tested unless otherwise stated.
 The authenticity of the test report, contact shchoi@kes.co.kr

Limit (Clause 4.2.6.2)

Table D.1: DFS requirement values

Parameter	Value
Channel Availability Check Time	60 s (see note 1)
Minimum Off-Channel CAC Time	6 minutes (see note 2)
Maximum Off-Channel CAC Time	4 hours (see note 2)
Channel Move Time	10 s
Channel Closing Transmission Time	1 s
Non-Occupancy Period	30 minutes
NOTE 1: For channels whose nominal bandwidth falls completely or partly within the band 5 600 MHz to 5 650 MHz, the <i>Channel Availability Check Time</i> shall be 10 minutes.	
NOTE 2: For channels whose nominal bandwidth falls completely or partly within the band 5 600 MHz to 5 650 MHz, the <i>Off-Channel CAC Time</i> shall be within the range 1 hour to 24 hours.	

Table D.2: Radar Detection Threshold Levels

e.i.r.p. Spectral Density (dBm/MHz)	Value (see note 1 and note 2)
10	-62 dBm
NOTE 1: This is the level at the input of the receiver of an RLAN device with a maximum e.i.r.p. density of 10 dBm/MHz and assuming a 0 dBi receive antenna. For devices employing different e.i.r.p. spectral density and/or a different receive antenna gain G (dBi) the Radar Detection Threshold Level at the receiver input follows the following relationship: $\text{DFS Detection Threshold (dBm)} = -62 + 10 \cdot \text{e.i.r.p. Spectral Density (dBm/MHz)} + G \text{ (dBi)}$ however the Radar Detection Threshold Level shall not be less than -64 dBm assuming a 0 dBi receive antenna gain.	
NOTE 2: Slave devices with a maximum e.i.r.p. of less than 23 dBm do not have to implement radar detection unless these devices are used in fixed outdoor point to point or fixed outdoor point to multipoint applications (see clause 4.2.6.1.3).	

Table D.3: Parameters of the reference DFS test signal

Pulse width W (μs)	Pulse repetition frequency PRF (PPS)	Pulses per burst (PPB)
1	700	18

This report shall not be reproduced except in full, without the written approval of KES Co., Ltd.
 The results shown in this test report refer only to the sample(s) tested unless otherwise stated.
 The authenticity of the test report, contact shchoi@kes.co.kr

Table D.4: Parameters of radar test signals

Radar test signal # (see note 1 to note 3)	Pulse width W (μs)		Pulse repetition frequency PRF (PPS)		Number of different PRFs	Pulses per burst for each PRF (PPB) (see note 5)
	Min	Max	Min	Max		
1	0,5	5	200	1 000	1	10 (see note 6)
2	0,5	15	200	1 600	1	15 (see note 6)
3	0,5	15	2 300	4 000	1	25
4	20	30	2 000	4 000	1	20
5	0,5	2	300	400	2/3	10 (see note 6)
6	0,5	2	400	1 200	2/3	15 (see note 6)

NOTE 1: Radar test signals #1 to #4 are constant PRF based signals. See figure D.1. These radar test signals are intended to simulate also radars using a packet based Staggered PRF. See figure D.2.

NOTE 2: Radar test signal #4 is a modulated radar test signal. The modulation to be used is a chirp modulation with a ±2,5 MHz frequency deviation which is described below.

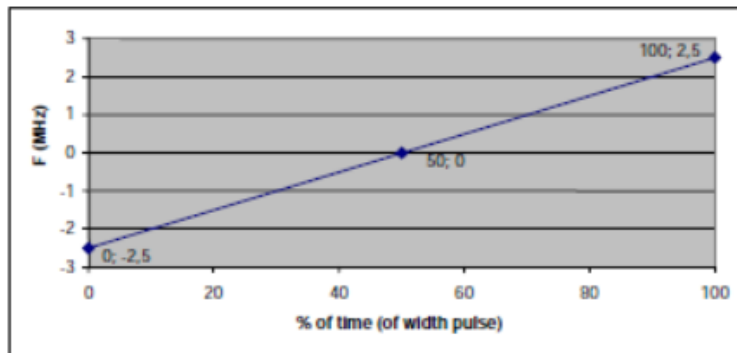

NOTE 3: Radar test signals #5 and #6 are single pulse based Staggered PRF radar test signals using 2 or 3 different PRF values. For radar test signal #5, the difference between the PRF values chosen shall be between 20 PPS and 50 PPS. For radar test signal #6, the difference between the PRF values chosen shall be between 80 PPS and 400 PPS. See figure D.3.

NOTE 4: Apart for the Off-Channel CAC testing, the radar test signals above shall only contain a single burst of pulses. See figure D.1, figure D.3 and figure D.4. For the Off-Channel CAC testing, repetitive bursts shall be used for the total duration of the test. See figure D.2 and figure D.5. See also clause 4.2.6.2.3, clause 5.4.8.2.1.4.2 and clause 5.4.8.2.1.4.3.

NOTE 5: The total number of pulses in a burst is equal to the number of pulses for a single PRF multiplied by the number of different PRFs used.

NOTE 6: For the CAC and Off-Channel CAC requirements, the minimum number of pulses (for each PRF) for any of the radar test signals to be detected in the band 5 600 MHz to 5 650 MHz shall be 18.

Table D.5: Detection probability

Parameter	Detection Probability (P_d)	
	Channels whose nominal bandwidth falls partly or completely within the 5 600 MHz to 5 650 MHz band	Other channels
CAC, Off-Channel CAC	99,99 %	60 %
In-Service Monitoring	60 %	60 %
NOTE: P_d gives the probability of detection per simulated radar burst and represents a minimum level of detection performance under defined conditions. Therefore P_d does not represent the overall detection probability for any particular radar under real life conditions.		

This report shall not be reproduced except in full, without the written approval of KES Co., Ltd.
 The results shown in this test report refer only to the sample(s) tested unless otherwise stated.
 The authenticity of the test report, contact shchoi@kes.co.kr

4.8. Adaptivity

Measurement Condition

Ambient temperature : 24.0
 Relative humidity : 40.2 % R.H.

Test procedure

EN 301 893 clause 5.4.9 – clause 5.4.9.2 or 5.4.9.3
 Used test method is clause 5.4.9.3

5.4.9.3 Test method for Load Based Equipment

5.4.9.3.2 Conducted measurements
 5.4.9.3.2.1 Initialization of the test

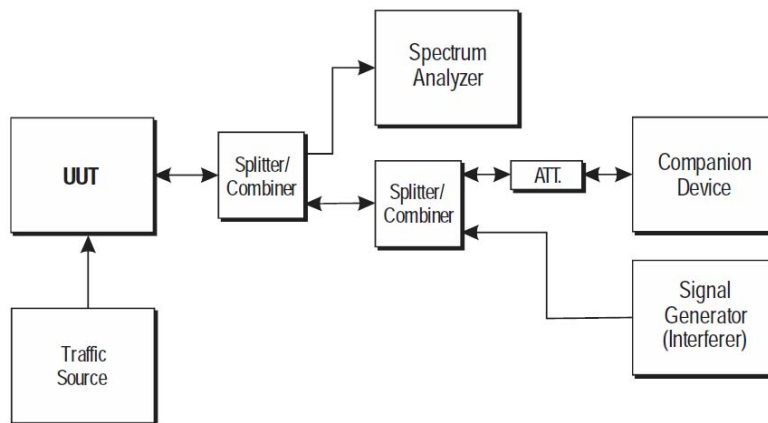

Figure 1 : Example Test Set-up for verifying the adaptivity of an equipment

The different steps below define the procedure to verify the efficiency of the adaptivity mechanism of the equipment.

Step 1:

- The UUT shall connect to a companion device during the test. The signal generator, the spectrum analyser, the UUT, the traffic source and the companion device are connected using a Set-up equivalent to the example given by figure 1 although the interference source is switched off at this point in time. The spectrum analyser is used to monitor the transmissions of the UUT in response to the interference signal. The traffic source might be part of the UUT itself.
- The received signal level (wanted signal from the companion device) at the UUT shall be sufficient to maintain a reliable link for the duration of the test. A typical value for the received signal level which can be used in most cases is -50 dBm/MHz.

· The analyser shall be set as follows:

1. RBW : \geq Occupied channel bandwidth (if the analyser does not support this setting, the highest available setting shall be used)
2. VBW : $3 \times$ RBW (if the analyser does not support this setting, the highest available setting shall be used)
3. Detector mode : RMS
4. Centre frequency : Equal to the centre frequency of the operating channel
5. Span : 0 Hz
6. Sweep time : $> 2 \times$ Channel occupancy time
7. Trace mode : Clear/Write
8. Trigger mode : Video or RF/IF power

Step 2:

- Configure the traffic source so that it exceeds the UUT's theoretical radio performance. The traffic source shall fill the UUT's buffers causing the UUT to always have transmissions queued (full buffer condition) towards the companion device. To avoid adverse effects on the measurement results, a unidirectional traffic source should be used. An example of such a unidirectional traffic source not triggering reverse traffic on higher layer protocols is UDP.

4.8.1 Channel operation of EUT device type

<input type="checkbox"/> Frame based equipment	<input type="checkbox"/> Multi-channel operation
<input checked="" type="checkbox"/> Load based equipment	<input type="checkbox"/> Single-channel operation
	<input checked="" type="checkbox"/> Option 1 for Multi-channel operation
	<input type="checkbox"/> Option 2 for Multi-channel operation

Mode: 802.11ac

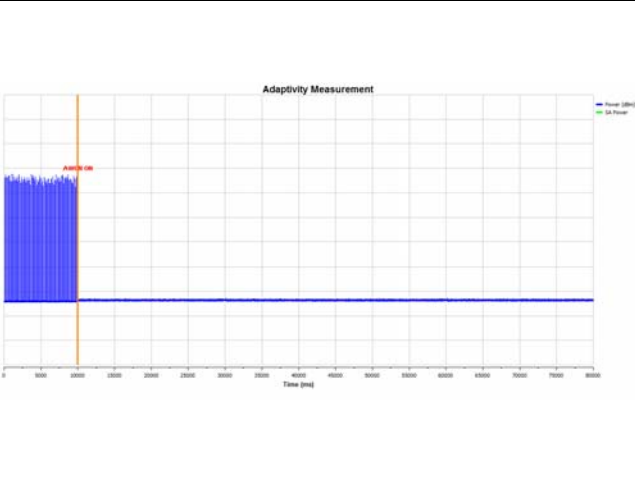
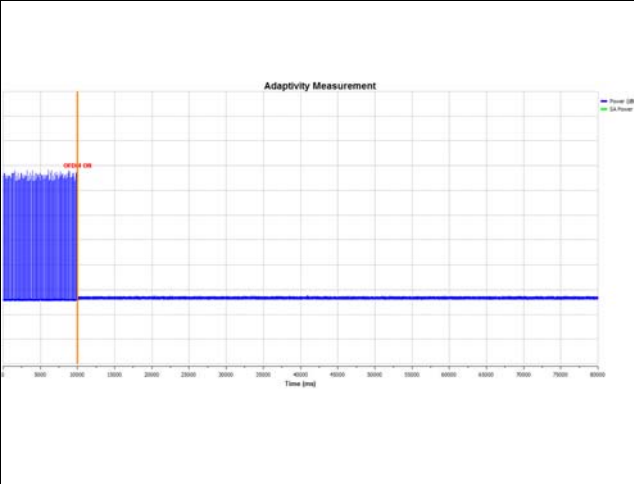
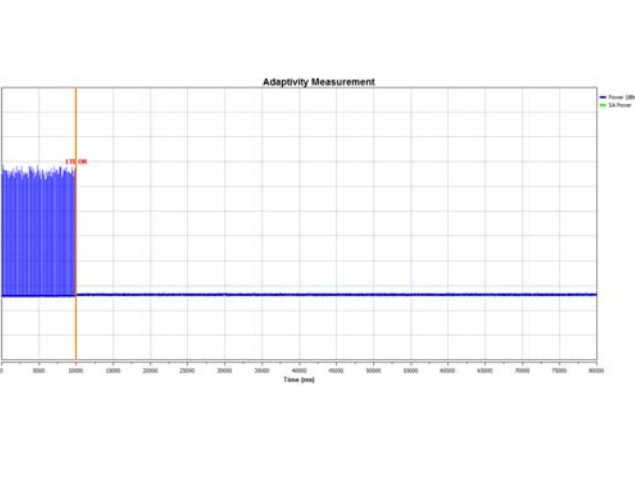
Additive White Gaussian Noise(AWGN)	OFDM
	
LTE	Blank
	

This report shall not be reproduced except in full, without the written approval of KES Co., Ltd.
 The results shown in this test report refer only to the sample(s) tested unless otherwise stated.
 The authenticity of the test report, contact shchoi@kes.co.kr

4.8.2 Medium Access Mechanism of EUT type

<input type="checkbox"/> Frame based equipment	
<input checked="" type="checkbox"/> Load based equipment	<input checked="" type="checkbox"/> Option A : Verify medium access mechanism
	<input type="checkbox"/> Option B : Declaration by manufacturer

4.8.3. Test result

Test item	Tested frequency (MHz)	Item	Values	Limit	
Adaptivity (before the interference signal)	5 180	Channel occupancy time	1.1 ms	< 2 ms	
	5 180	Idle period	26 μs	> 25 μs	
Adaptivity (adding the interference signal)	5 180	AWGN	Stop transmissions	Stop transmission on the current operating channel	
		OFDM			
		LTE			
	5 180	AWGN	Short control signaling transmission	No transmission	Short Control Signalling Transmissions of Adaptive equipment shall have a maximum duty cycle of 5 % within an observation period of 50 ms
		OFDM			
		LTE			

This report shall not be reproduced except in full, without the written approval of KES Co., Ltd.
 The results shown in this test report refer only to the sample(s) tested unless otherwise stated.
 The authenticity of the test report, contact shchoi@kes.co.kr

Limit (Clause 4.2.7.3.2)

4.2.7.3.2.4 Priority classes

Table 1 : Priority class dependent channel access parameters for supervising devices.

Class #	P ₀	CW _{min}	CW _{max}	Maximum Channel Occupancy Time (COT)
4	1	3	7	2 ms
3	1	7	15	4 ms
2	3	15	63	6 ms (see note 1 and note 2)
1	7	15	1 023	6 ms (see note 1)
Note 1 :	The maximum Channel Occupancy Time (COT) of 6 ms may be increased to 8 ms by inserting one or more pauses. The minimum duration of a pause shall be 100 μs. The maximum duration (Channel Occupancy) before including any such pause shall be 6 ms. Pause duration is not included in the channel occupancy time.			
Note 2 :	The maximum Channel Occupancy Time (COT) of 6 ms may be increased to 10 ms by extending CW to CW × 2+1 when selecting the random number q for any backoff(s) that precede the Channel Occupancy that may exceed 6 ms or which follow the Channel Occupancy that exceeded 6 ms. The choice between preceding or following a Channel Occupancy shall remain unchanged during the operation time of the device.			
Note 3 :	The value for P ₀ , CW _{min} , CW _{max} are minimum values. Greater values are allowed.			

Table 2 : Classification of idle periods dependent priority class for supervising devices.

Class #	Idle Periods Classification
4	$B_n = \begin{cases} [0, 23[\mu s, n = 0 \\ [23 + 9 \times (n - 1), 23 + 9 \times n[\mu s, 1 \leq n \leq 3 \\ [50, \infty[\mu s, n = 4 \end{cases}$
3	$B_n = \begin{cases} [0, 23[\mu s, n = 0 \\ [23 + 9 \times (n - 1), 23 + 9 \times n[\mu s, 1 \leq n \leq 7 \\ [86, \infty[\mu s, n = 8 \end{cases}$
2	$B_n = \begin{cases} [0, 41[\mu s, n = 0 \\ [41 + 9 \times (n - 1), 41 + 9 \times n[\mu s, 1 \leq n \leq 31 \\ [320, \infty[\mu s, n = 32 \end{cases}$
1	$B_n = \begin{cases} [0, 77[\mu s, n = 0 \\ [77 + 9 \times (n - 1), 77 + 9 \times n[\mu s, 1 \leq n \leq 15 \\ [212, \infty[\mu s, n = 16 \end{cases}$

Table 3 : Priority class dependent channel access parameters for supervised devices.

Class #	P ₀	CW _{min}	CW _{max}	Maximum Channel Occupancy Time (COT)
4	2	3	7	2 ms
3	2	7	15	4 ms
2	3	15	1 023	6 ms (see note 1)
1	7	15	1 023	6 ms (see note 1)
Note 1 :	The maximum Channel Occupancy Time (COT) of 6 ms may be increased to 8 ms by inserting one or more pauses. The minimum duration of a pause shall be 100 μs. The maximum duration (Channel Occupancy) before including any such pause shall be 6 ms. Pause duration is not included in the channel occupancy time.			
Note 2 :	The value for P ₀ , CW _{min} , CW _{max} are minimum values. Greater values are allowed.			

Table 4 : Classification of idle periods dependent priority class for supervised devices.

Class #	Idle Periods Classification
4	$B_n = \begin{cases} [0, 32[\mu\text{s}, n = 0 \\ [32 + 9 \times (n - 1), 32 + 9 \times n[\mu\text{s}, 1 \leq n \leq 3 \\ [59, \infty[\mu\text{s}, n = 4 \end{cases}$
3	$B_n = \begin{cases} [0, 32[\mu\text{s}, n = 0 \\ [32 + 9 \times (n - 1), 32 + 9 \times n[\mu\text{s}, 1 \leq n \leq 7 \\ [95, \infty[\mu\text{s}, n = 8 \end{cases}$
2	$B_n = \begin{cases} [0, 41[\mu\text{s}, n = 0 \\ [41 + 9 \times (n - 1), 41 + 9 \times n[\mu\text{s}, 1 \leq n \leq 15 \\ [176, \infty[\mu\text{s}, n = 16 \end{cases}$
1	$B_n = \begin{cases} [0, 77[\mu\text{s}, n = 0 \\ [77 + 9 \times (n - 1), 77 + 9 \times n[\mu\text{s}, 1 \leq n \leq 15 \\ [212, \infty[\mu\text{s}, n = 16 \end{cases}$

Idle period probability evaluation.

- Let $H(B_n)$ define the number of Idle Periods assigned to bin B_n .
- Let E define the total number of Idle periods observed. Then E is the sum of events in all bins:

$$E = \sum_{n=0}^k H(B_n)$$

- Calculate the observed cumulative probabilities as follows:
 - Let $P(n)$ define the probability that idle periods of duration less than the upper limit specified for bin B_n Occurred, $P(n) = P(\text{Idle period} < \text{upper limit of bin } B_n)$.
 - Then, for each $n, 0 \leq n \leq k$, calculate $P(n)$ as:

$$p(n) = \frac{\sum_{i=0}^n H(B_i)}{E}$$

- It shall be verified whether the UUT complies with the below maximum probabilities:

Table 5 : Idle periods probability dependent priority class

Class #	Idle Periods probability
4	$p(n) \leq \begin{cases} 0,05, & n = 0 \\ 0,05 + n \times 0,25, & 1 \leq n \leq 3 \\ 1, & n > 3 \end{cases}$
3	$p(n) \leq \begin{cases} 0,05, & n = 0 \\ 0,18, & n = 1 \\ 0,18 + (n - 1) \times 0,125, & 2 \leq n \leq 6 \\ 1, & n > 6 \end{cases}$
2	$p(n) \leq \begin{cases} 0,05, & n = 0 \\ 0,12, & n = 1 \\ 0,12 + (n - 1) \times 0,03125, & 2 \leq n \leq 29 \\ 1, & n > 29 \end{cases}$ $p(n) \leq \begin{cases} 0,05, & n = 0 \\ 0,12, & n = 1 \\ 0,12 + (n - 1) \times 0,0625, & 2 \leq n \leq 15 \\ 1, & n > 15 \end{cases}$ $p(n) \leq \begin{cases} 0,05, & n = 0 \\ 0,09 + (n - 1) \times 0,03125, & 1 \leq n \leq 7 \\ 0,59 + (n - 1) \times 0,03125, & 8 \leq n \leq 14 \\ 1, & n > 14 \end{cases}$
1	$p(n) \leq \begin{cases} 0,05, & n = 0 \\ 0,12, & n = 1 \\ 0,12 + (n - 1) \times 0,0625, & 2 \leq n \leq 15 \\ 1, & n > 15 \end{cases}$

4.2.7.3.2.5 ED Threshold level (Energy Detection Threshold Level)

Option 1 : For equipment that for its operation in the 5 GHz bands is conforming to IEEE 802.11™-2016[9], clause 17, Clause 19 or clause 21, or any combination of these clause, the ED Threshold Level (TL) is independent of The equipment's maximum transmit power (P_H). Assuming a 0 dBi receive antenna the ED Threshold Level (TL) shall be:

$$TL = -75 \text{ dBm/MHz}$$

Option 2 : For equipment conforming to one or more of the clauses listed in Option 1, and to at least one other operating mode, and for equipment conforming to none of the clauses listed in Option 1, the ED Threshold Level (TL) shall be proportional to the equipment's maximum transmit power (P_H).

Assuming a 0 dBi receive antenna the ED Threshold Level (TL) shall be:

$$\begin{aligned} \text{For } P_H \leq 13 \text{ dBm} : TL &= -75 \text{ dBm/MHz} \\ \text{For } 13 \text{ dBm} < P_H < 23 \text{ dBm} : TL &= -85 \text{ dBm/MHz} + (23 \text{ dBm} - P_H) \quad (3) \\ \text{For } P_H \geq 23 \text{ dBm} : TL &= -85 \text{ dBm/MHz} \end{aligned}$$

Equipment shall consider a channel to be occupied as long as other RLAN transmissions are detected at a level greater than the TL.

4.2.7.3.3 Short control signalling transmissions (FBE and LBE)

The use of Short Control Signalling Transmissions is constrained as follows:

- within an observation period of 50 ms, the number of short control signaling transmissions by the equipment shall Be equal to or less than 50; and
- the total duration of the equipment's short control signaling transmissions shall be less than 2 500 μ s within said Observation period.

4.9. Receiver blocking

Measurement Condition

Ambient temperature : 24.0 °C
 Relative humidity : 40.2 % R.H.

Test procedure

EN 301 893 clause 5.4.10.2

5.4.10.2.1

Conducted measurements

For systems using multiple receive chains only one chain need to be tested. All other receiver inputs shall be terminated.

Figure 18 shows the test set-up which can be used for performing the receiver blocking test. The companion device may require appropriate shielding or may need to be put in a shielded room to prevent it may have a negative impact on the measurement.

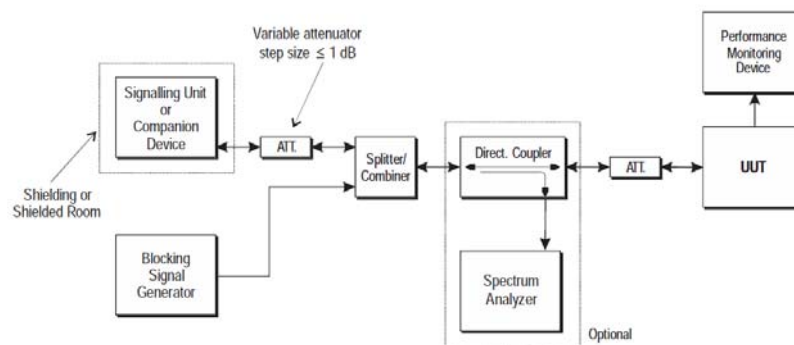

Figure 18: Test Set-up for receiver blocking

The steps below define the procedure to verify the receiver blocking requirement as described in clause 4.2.8.

Step 1:

- The UUT shall be set to the first operating frequency to be tested (see clause 5.3.2).

Step 2:

- The blocking signal generator is set to the first frequency as defined in table 9.

Step 3:

- With the blocking signal generator switched off a communication link is set up between the UUT and the associated companion device using the test setup shown in figure 18. The attenuation of the variable attenuator shall be increased in 1 dB steps to a value at which the minimum performance criteria as specified in clause 4.2.8.3 is still met. The resulting level for the wanted signal at the input of the UUT is P_{min} .
- This signal level (P_{min}) is increased by 6 dB resulting in a new level ($P_{min} + 6$ dB) of the wanted signal at the UUT receiver input.

Step 5:

- Repeat step 4 for each remaining combination of frequency and level as specified in table 9.

Step 6:

- Repeat step 2 to step 5 with the UUT operating at the other operating frequencies at which the blocking test has to be performed. See clause 5.3.2.



Test results

Mode: 802.11aRX Channel	Int. Freq. (MHz)	Int. Lev. (dB m)	Int. Signal	Verdict
Lowest	5100.0	-53	CW	Pass
Lowest	4900.0	-47	CW	Pass
Lowest	5000.0	-47	CW	Pass
Lowest	5975.0	-47	CW	Pass
Highest	5100.0	-53	CW	Pass
Highest	4900.0	-47	CW	Pass
Highest	5000.0	-47	CW	Pass
Highest	5975.0	-47	CW	Pass

This report shall not be reproduced except in full, without the written approval of KES Co., Ltd.
The results shown in this test report refer only to the sample(s) tested unless otherwise stated.
The authenticity of the test report, contact shchoi@kes.co.kr

Limit (Clause 4.2.8.4)

While maintaining the minimum performance criteria as defined in clause 4.2.8.3, the blocking levels at specified frequency offsets shall be equal to or greater than the limits defined in table 9.

Table 9: Receiver Blocking parameters

Wanted signal mean power from companion device (dBm)	Blocking signal frequency(MHz)	Blocking signal power(dBm) (see note 2)		Type of blocking signal
		Master or Slave with radar detection (as defined in ETSI EN 301 893 [1], table D.2, note 2)	Slave without radar detection (as defined in ETSI EN 301 893 [1], table D.2, note 2)	
$P_{min} + 6$ dB	5100	-53	-59	Continuous Wave
$P_{min} + 6$ dB	4900 5000 5975	-47	-53	Continuous Wave

NOTE 1: P_{min} is the minimum level of the wanted signal (in dBm) required to meet the minimum performance criteria as defined in clause 4.1.2 in the absence of any blocking signal.

NOTE 2: The levels specified are levels in front of the UUT antenna. In case of conducted measurements, the levels have to be corrected by the actual antenna assembly gain.



Appendix A.

Measurement equipment



KES Co., Ltd.

3701, 40, Simin-daero 365beon-gil,
Dongan-gu, Anyang-si, Gyeonggi-do, 14057, Korea
Tel: +82-31-425-6200 / Fax: +82-31-424-0450
www.kes.co.kr

Report No.:
KES-RF-18T0119
Page (98) of (107)

Equipment	Manufacturer	Model	Serial No.	Calibration interval	Calibration due.
Spectrum analyzer	R&S	FSV40	101002	1 year	2019.06.29
Spectrum analyzer	Agilent	N9020A	MY52091086	1 year	2019.01.19
USB Wideband Power Sensor	Agilent	U2021XA	MY54260004	1 year	2019.01.19
USB Wideband Power Sensor	Agilent	U2021XA	MY54340004	1 year	2019.01.19
USB Wideband Power Sensor	Agilent	U2021XA	MY54390010	1 year	2019.01.19
USB Wideband Power Sensor	Agilent	U2021XA	MY54390009	1 year	2019.01.19
Signal generator	Agilent	N5182A	MY50143493	1 year	2019.01.18
Signal generator	Agilent	N5182A	MY50143829	1 year	2019.01.18
8360B Series Swept Signal Generator	HP	83630B	3844A00786	1 year	2019.01.22
DC Power Supply	Agilent	6632B	US36351824	1 year	2019.01.18
Trilog-broadband antenna	SCHWARZBECK	VULB 9163	714	2 years	2020.11.26
Dipole antenna	SCHWARZBECK	VHA9103	3093	2 years	2019.05.19
Dipole antenna	SCHWARZBECK	UHA9105	2703	2 years	2019.05.19
Dipole antenna	SCHWARZBECK	VHA9103	3101	2 years	2019.05.19
Dipole antenna	SCHWARZBECK	UHA9105	2702	2 years	2019.05.19
Horn Antenna	A.H.	SAS-571	781	2 years	2019.05.02
Horn Antenna	A.H SYSTEMS	SAS-571	414	2 years	2019.02.15
Preamplifier	R&S	SCU01	100603	1 year	2019.11.26
Preamplifier	HP	8447F	2805A02570	1 year	2019.01.18
Attenuator	KEYSIGHT	8493C	82506	1 year	2019.01.18
High Pass Filter	WAINWRIGHT INSTRUMENT	WHJS3000-10TT	1	1 year	2019.06.29
Low Pass Filter	WEINSHEL	WLK1.0/18G-10TT	1	1 year	2019.06.29
Splitter	MINI-CIRCUITS	ZFSC-2-10G+	F679501347-1	1 year	2019.06.28
Splitter	MINI-CIRCUITS	ZFSC-2-10G+	F679501347-2	1 year	2019.06.28
Dual Directional Coupler	KRYTAR	152613	153577	1 year	2019.06.28

Peripheral devices

Device	Manufacturer	Model No.	Serial No.
Notebook Computer	Samsung Electronics Co., Ltd.	RV518	HTK991NC600207R
Access point	DASAN Network Solutions, Inc.	H680GW	N/A

This report shall not be reproduced except in full, without the written approval of KES Co., Ltd.
The results shown in this test report refer only to the sample(s) tested unless otherwise stated.
The authenticity of the test report, contact shchoi@kes.co.kr



Appendix B.

Test setup photos

Below 1 GHz



Above 1 GHz



This report shall not be reproduced except in full, without the written approval of KES Co., Ltd.
The results shown in this test report refer only to the sample(s) tested unless otherwise stated.
The authenticity of the test report, contact shchoi@kes.co.kr



Appendix C.

EUT photos

This report shall not be reproduced except in full, without the written approval of KES Co., Ltd.
The results shown in this test report refer only to the sample(s) tested unless otherwise stated.
The authenticity of the test report, contact shchoi@kes.co.kr



This report shall not be reproduced except in full, without the written approval of KES Co., Ltd.
The results shown in this test report refer only to the sample(s) tested unless otherwise stated.
The authenticity of the test report, contact shchoi@kes.co.kr

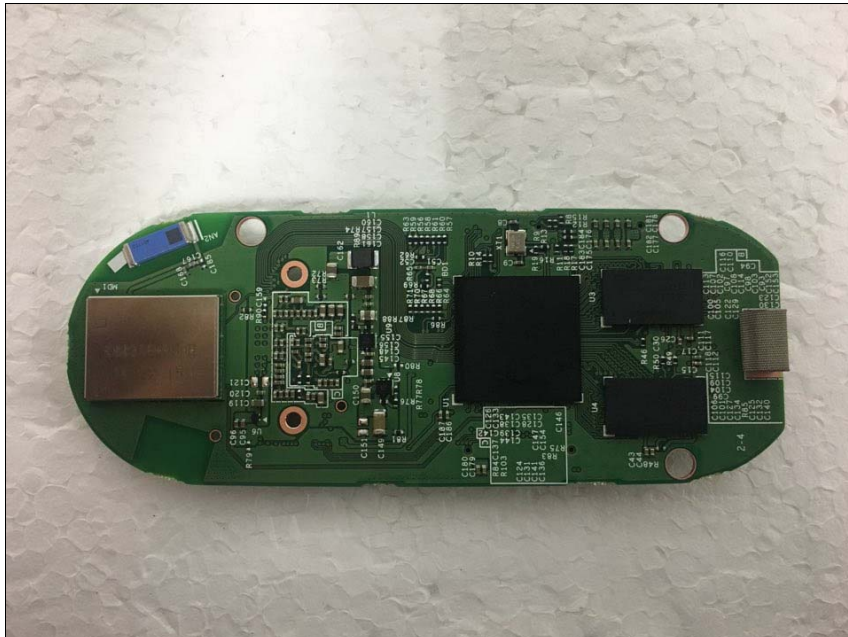

This report shall not be reproduced except in full, without the written approval of KES Co., Ltd.
The results shown in this test report refer only to the sample(s) tested unless otherwise stated.
The authenticity of the test report, contact shchoi@kes.co.kr

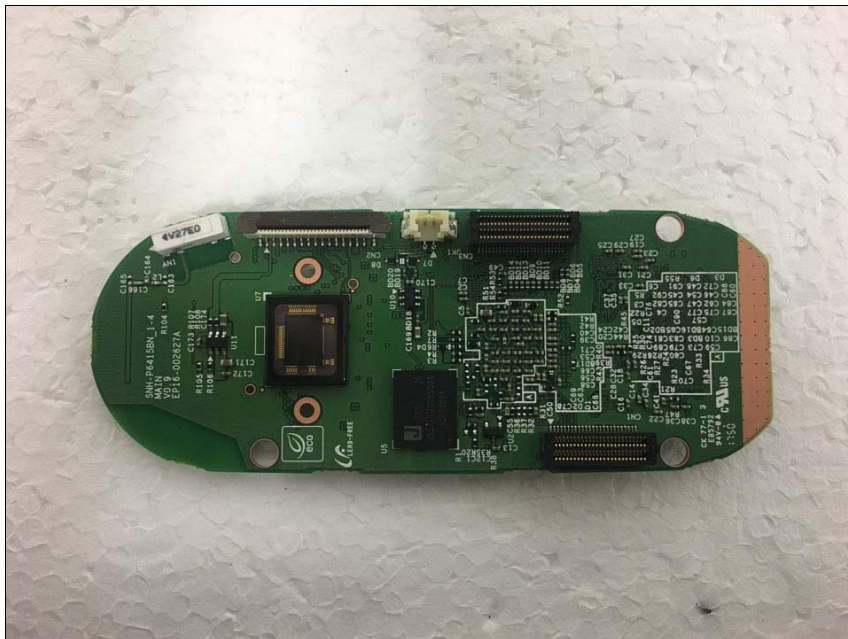
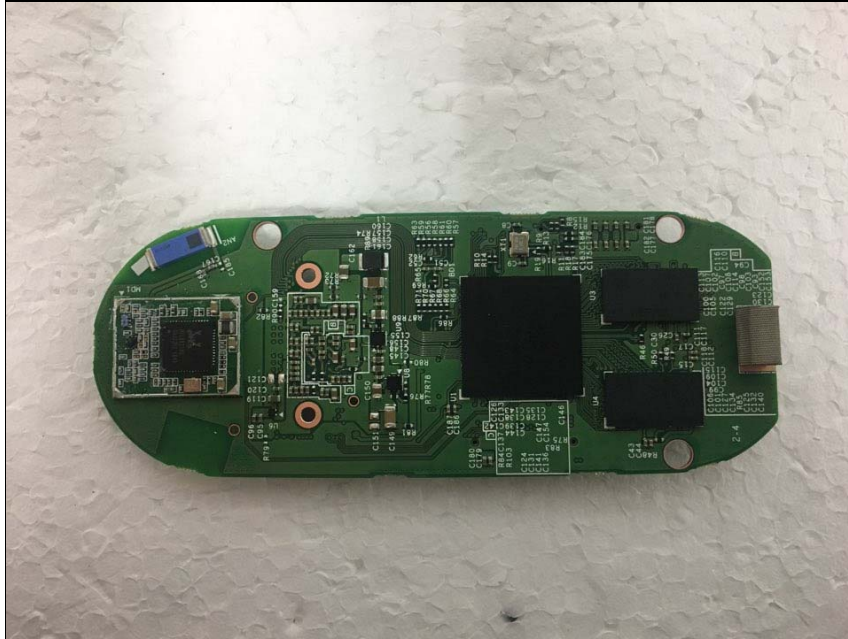

This report shall not be reproduced except in full, without the written approval of KES Co., Ltd.
The results shown in this test report refer only to the sample(s) tested unless otherwise stated.
The authenticity of the test report, contact shchoi@kes.co.kr



This report shall not be reproduced except in full, without the written approval of KES Co., Ltd.
The results shown in this test report refer only to the sample(s) tested unless otherwise stated.
The authenticity of the test report, contact shchoi@kes.co.kr

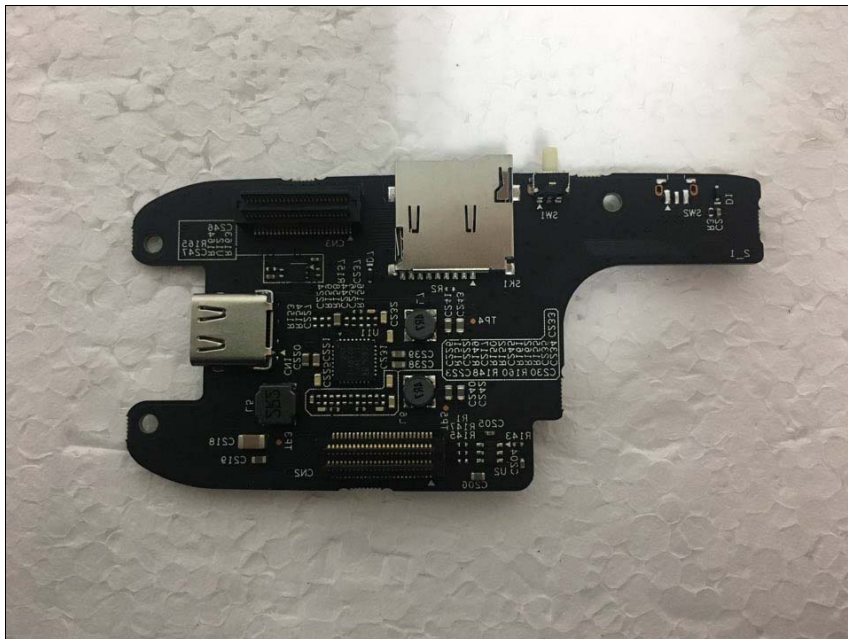
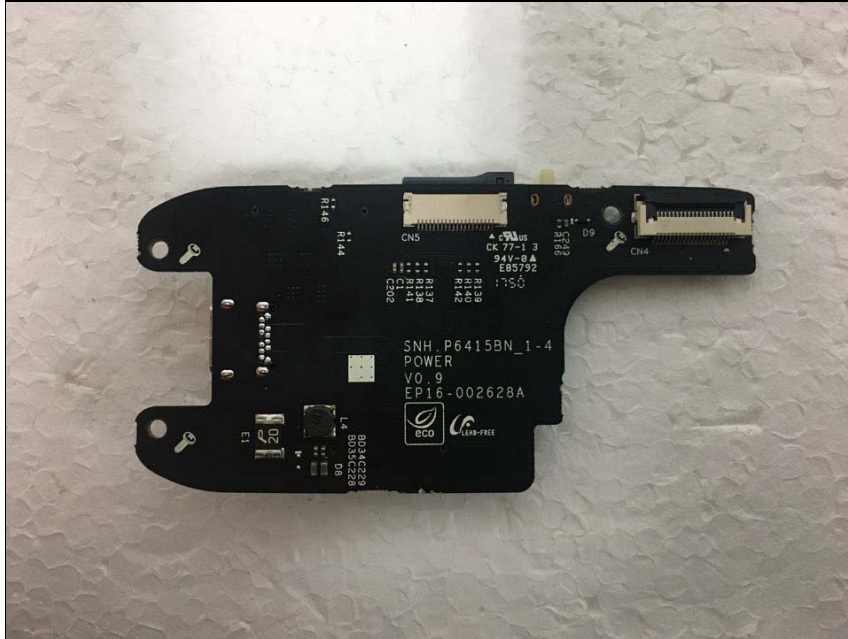

The end of test report.

This report shall not be reproduced except in full, without the written approval of KES Co., Ltd.
The results shown in this test report refer only to the sample(s) tested unless otherwise stated.
The authenticity of the test report, contact shchoi@kes.co.kr